

# SERVICE MANUAL

FOR

LK3-B220 SERIES

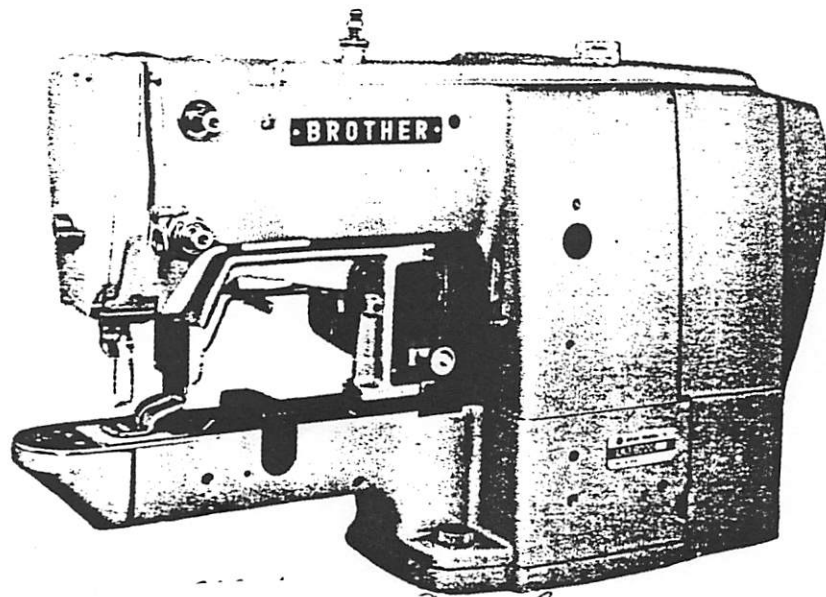

**BROTHER INDUSTRIES, LTD.**

**NAGOYA, JAPAN**

## **PREFACE**

This service manual is composed of three chapters, Mechanism, Adjustment and Trouble Shooting. The majority of the servicing problems can be solved with the knowledge on the instruction book which is included with this machine. In order to be acquainted with this machine perfectly, please read this service manual carefully together with the parts catalogue, then we hope you would get full knowledge on this machine and you could solve troubles if you would encounter any problems without any difficulties.

**BROTHER INDUSTRIES, LTD.**

# CONTENTS

<b>CHAPTER I MECHANISM.....</b>	<b>1</b>
1. Upper shaft, take-up lever, needle bar and hook mechanism .....	1
2. Feed mechanism .....	2
3. Thread trimming mechanism.....	4
4. Thread nipper mechanism .....	5
5. Work clamp lifting mechanism.....	7
6. Clutch mechanism.....	8
7. Safety mechanism.....	10
<b>CHAPTER II ADJUSTMENT .....</b>	<b>11</b>
1. Adjustment on needle bar and shuttle hook mechanism.....	11
2. Adjustment on feed mechanism .....	14
3. Adjustment on clutch mechanism .....	16
4. Adjustment on work clamp mechanism.....	20
5. Adjustment on thread trimming mechanism.....	22
6. Adjustment on safety mechanism .....	26
7. Adjustment on thread nipper mechanism.....	28
8. Adjustment on drive mechanism.....	31
9. Adjustment on bobbin winder mechanism.....	32
<b>CHAPTER III TROUBLE SHOOTING.....</b>	<b>33</b>
1. Thread tension mechanism .....	33
2. Thread trimming mechanism.....	34
3. Clutch mechanism.....	35
4. Feed mechanism .....	36
5. Needle bar and hook mechanism .....	36

# CHAPTER I MECHANISM

## 1. Upper shaft, take-up lever, needle bar and hook mechanism

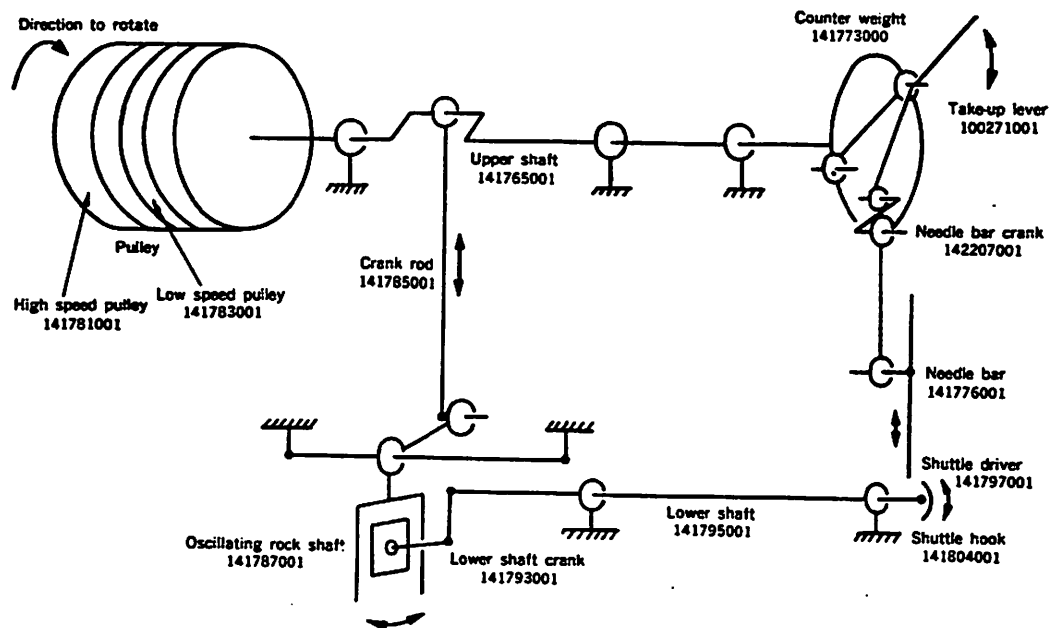

Rotating movement which is transmitted from the motor with the intermittent action of pulley (high speed pulley and low speed pulley) is changed into vertical movement of thread take-up lever and needle bar with the intermittent action of upper shaft and needle bar crank.

Other rotating movement transmitted to upper shaft is changed into oscillating movement of shuttle driver with the intermittent action of crank rod, oscillating rock body and lower shaft crank.

All the above mechanisms are designed to be durable at maximum high speed of 2,000 s.p.m. and Brother's own designed hook timing adjusting mechanism and noiseless mechanism on shuttle hook featured this machine.

Brother's own hook timing adjusting mechanism eliminates the conventional troublesome adjustment with washer to get proper clearance between needle and hook point. This fine adjustment is made merely by adjusting ring to get proper space. Namely, if you turn the shuttle hook adjusting ring, the shuttle race body moves with the aid of the screw thread pitched in the shuttle race adjusting ring. Thus, shuttle race and shuttle hook move to get the desired clearance. At that time, lower shaft and lower shaft crank move together with shuttle race body, therefore, it does not require any troublesome adjustment on hook timing.

And, in order to eliminate noise out of shuttle hook, the spring on shuttle driver is equipped with, thus you can get very quiet operation even at maximum high speed of 2,000 s.p.m.

## 2. Feed mechanism

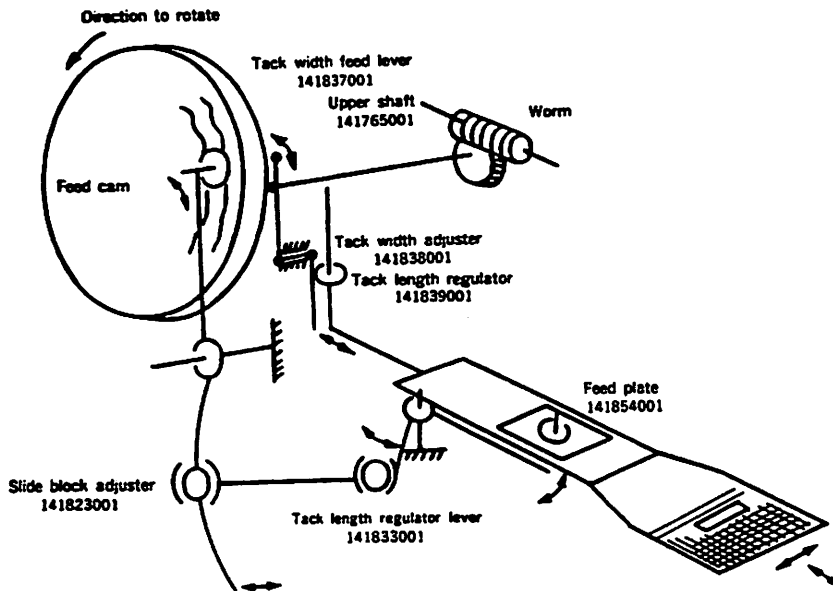

Worm set with upper shaft drives worm wheel and rotates the cam.

Tack width feed lever is connected with cam groove with roller and it brings oscillating movement in accordance with the rotation of feed cam. This oscillating movement is changed into linear movement of presser arm with the action of tack width adjuster and it brings back and forth movement.

Tack length lever is connected with cam groove with roller and it brings oscillating movement in accordance with the rotation of feed cam. This oscillating movement is changed into zigzag movement of presser arm with the action of tack length rod and tack length regulator lever. Both movements are transmitted to presser arm, thus it performs tack design in rectangular opening of work clamp.

This machine is designed not to cause the torn movement, thus all the mechanism are functioned smoothly.

**\* Adjusting tack width**

Tack width.....it defined the width of A as per illustration.

This adjustment is made by moving adjusting screw up or down.

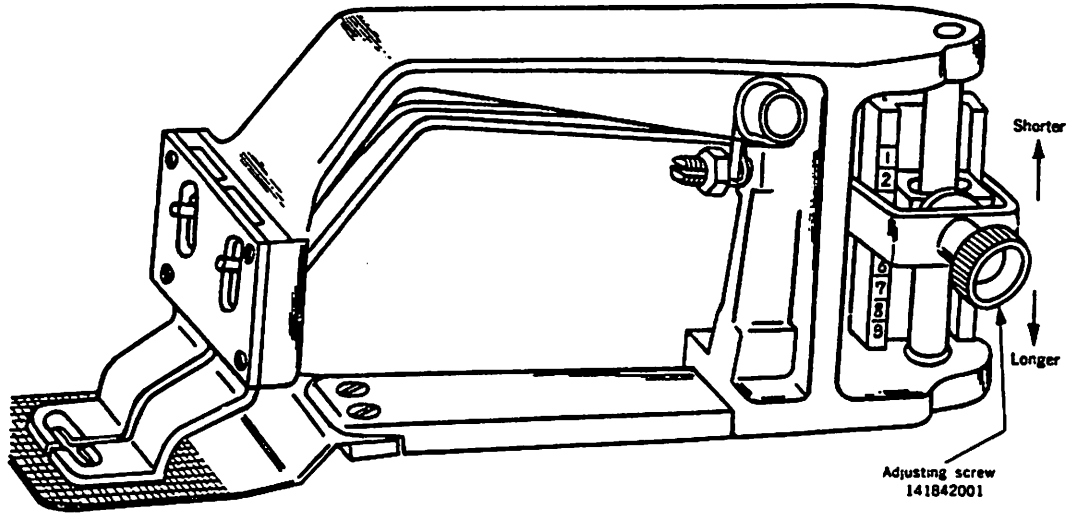
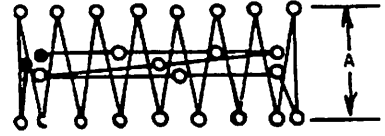

Tack length.....it defines the length of B as per illustration.

This adjustment is made by moving Thumb screw up or down.

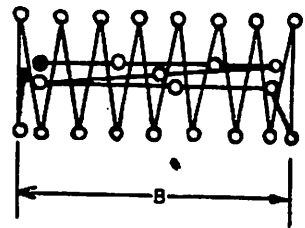
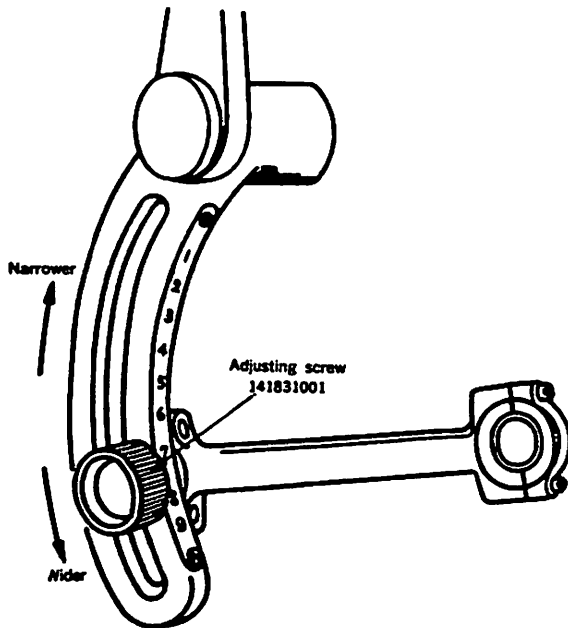

### 3. Thread trimming mechanism

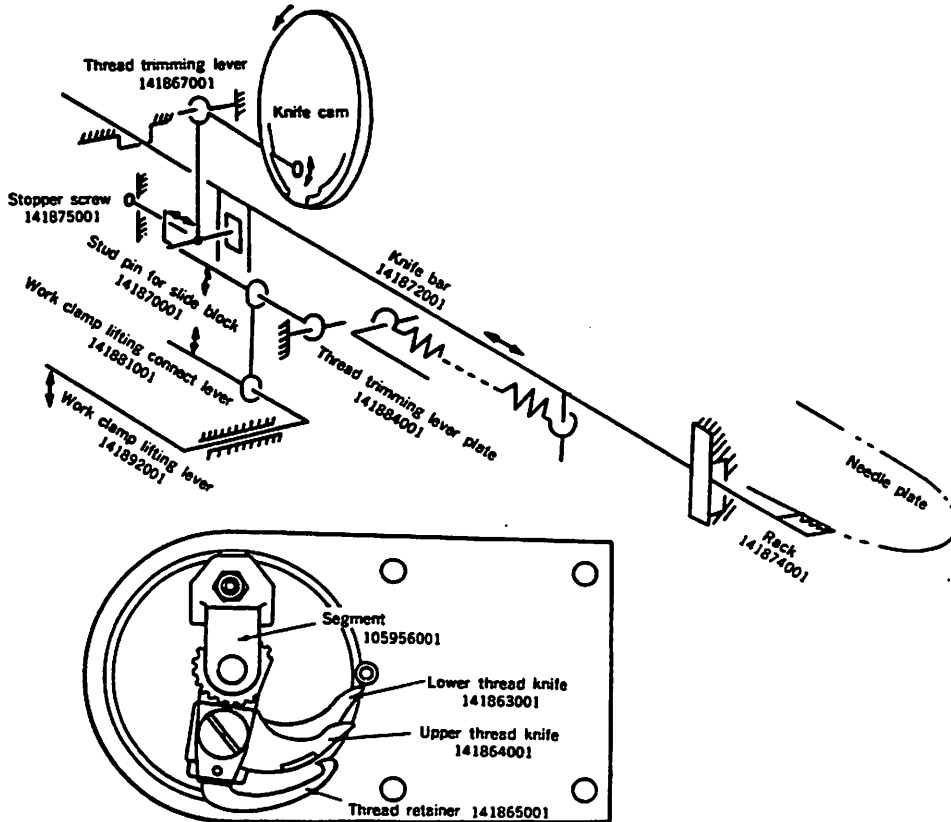

Knife cam assembled with feed cam operates the thread trimming lever when feed cam rotates and transmitted to the knives with the intermittent action of knife bar. At the stop position, the thread trimming knives are stationed with the thread hooked since thread trimming lever slide block stud pin contacts with thread trimming lever plate. When left treadle is depressed, thread trimming lever slide block stud pin is disengaged with thread trimming lever plate and knife bar is engaged with aid of spring and knives trim threads.

This machine adopts the thread trimming mechanism of movable knife action only, and features uniform thread tails almost same as the conventional scissor system being consisted of movable and fixed knives and ensures very stable thread trimming. This method becomes possible the knives to be replaced without much difficulties which is required on scissor system.

#### 4. Thread nipper mechanism

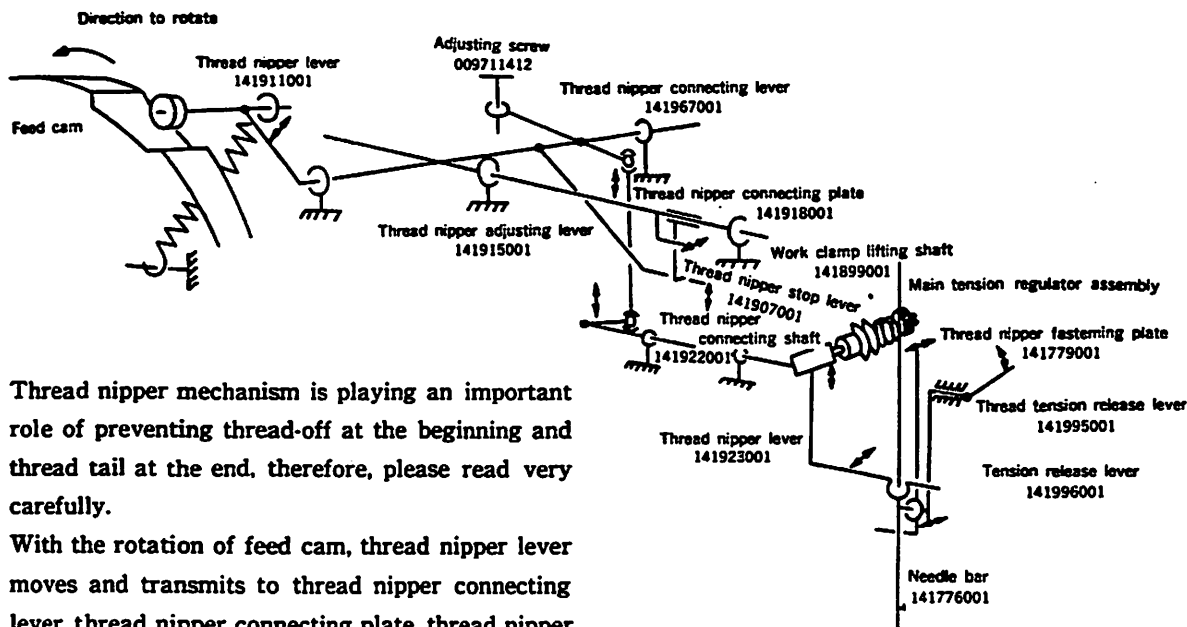

Thread nipper mechanism is playing an important role of preventing thread-off at the beginning and thread tail at the end, therefore, please read very carefully.

With the rotation of feed cam, thread nipper lever moves and transmits to thread nipper connecting lever, thread nipper connecting plate, thread nipper connecting shaft and thread nipper fastening plate and on the part of cam of thread nipper shaft, it releases the main tension regulator and with the thread nipper fastening plate, it tightens thread nipper spring on needle bar.

The motion of thread nipper spring on needle bar is connected with the work clamp lifting, therefore, at the stop position, thread nipper adjusting lever is engaged with thread nipper stop lever and it releases main tension regulator and thread nipper spring. And when work clamp lifting lever is depressed, work clamp lifting shaft rotates, stop lever is engaged and it tightens thread nipper spring.

The pressure on thread nipper spring is unable to be adjusted on the conventional model, however, this machine is capable to adjust it, thus, it brings good sewing effects and it widens the range of adjustments on different kinds of materials and threads. This adjustment of pressure can be easily done by spring adjusting plate.

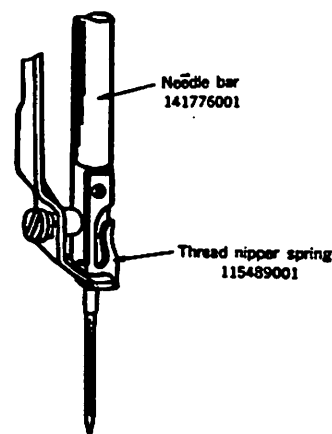
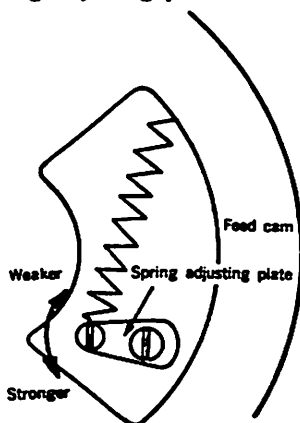



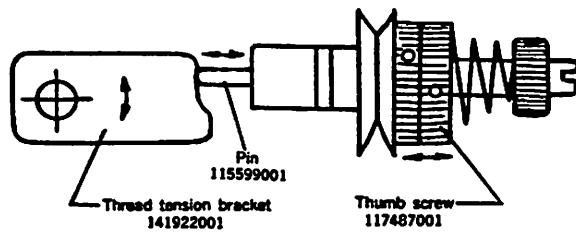

### Main tension regulator

In accordance with wider amount of main tension release, it widens the range of adjustment on main tension regulator, thus it enables to adjust the tension depending on the thickness of the thread. This mechanism is explained on the above illustration, that is, when bracket is rotated, the pin moves as per arrow followed with the thumb screw.

When you wish to release tension on thread nipper spring manually, just depress the handle on the face plate.

## 5. Work clamp lifting mechanism

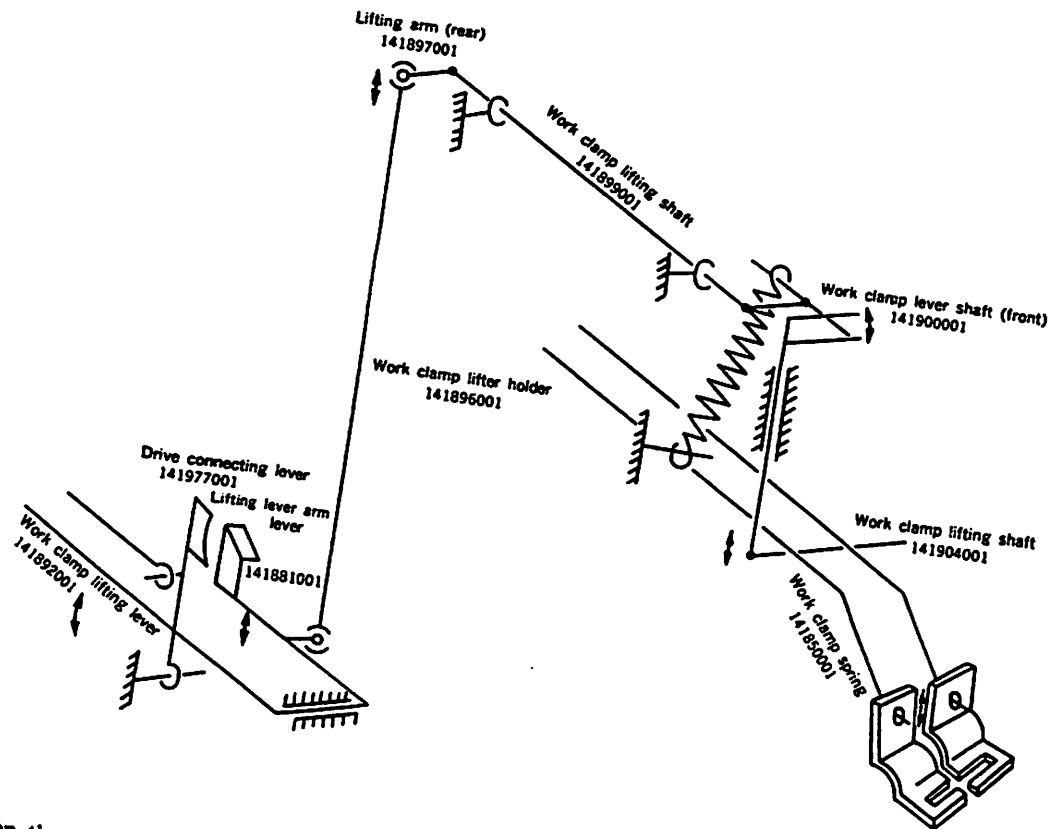

When the left treadle is depressed, work clamp lifter connecting lever makes work clamp spring lift up with the intermittent action of connecting bar, lifting arm (rear), work clamp lifting shaft and lifting arm (front). The work clamp spring is lifted by work clamp lifting lever, then work clamp is lifted up. And, when the treadle is released, work clamp is lowered. In comparison with the mechanism of the previous model, this newly designed mechanism works very smoothly without any heavy torque, thus it lessens the operator's fatigue considerably. Also, the setting of work clamp lifter holder is farther from needle bar, thus it ensures much wider working space than the previous models.

## 6. Clutch mechanism

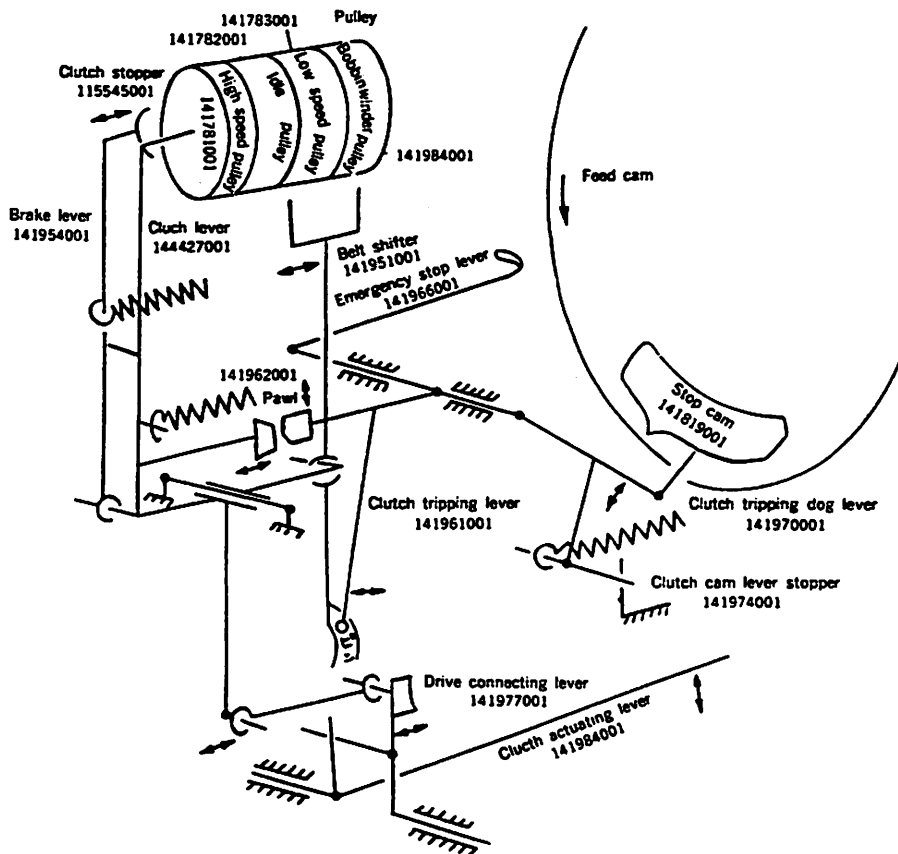

This model, LK3-B220 is adopted Brother's unique two driving belts system. The speed on starting and finishing is reduced so that the shock will be lessened when the machine is going to stop, and prevented thread-off at start, thus the newly developed mechanism is ensured to obtain smooth operation. Furthermore, this machine is adopted endless belts vertically which eliminate noise and vibration considerably.

- 1) At the stop position, by belt guide lever is positioned at idle pulley and bobbin winder pulley.
- 2) At the start, when you depress the actuating pedal, the actuating lever engages to work clutch actuating lever, connecting lever, connecting rod and disengages clutch. At that time, belts are positioned at low speed pulley and idle pulley and motion is transmitted to upper shaft.

Duration of speed reduction: 1~3 stitches

Speed of reduction: 800 s.p.m.

- 3) At sewing, it becomes high speed of 2,000 s.p.m. and by belt guide lever, belts are positioned at high speed pulley and idle pulley.
- 4) 5~6 stitches prior to the stop, it reduces the speed to 800 s.p.m. again and prevents thread breakage and shock at the stop.

One stitch before the end of one cycle of sewing, when tripping dog is over the stop cam bulge, clutch stop latch is disengaged with clutch lever catch, thus clutch is engaged. At that time, belts are positioned at bobbin winder pulley and idle pulley by belt guide lever, thus sewing cycle is completed and machine automatically stops.

5) Emergency stop lever

When you depressed emergency stop lever down, tripping dog which is assembled with emergency stop lever plays same role as mentioned above, thus machine stops.

## 7. Safety mechanism

This machine is designed to control the motion of lever to protect the machine from damage. Namely, even if the work clamp lift treadle is erroneously depressed while the machine is in operation, work clamp stays down and even if actuating treadle is erroneously depressed when work clamp is lifted up, the machine will not start.

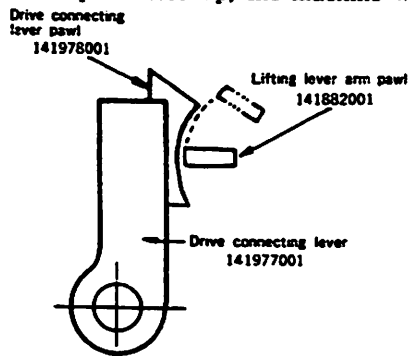

The left illustration shows that the work clamp lifts up, at this position, claw prevents the movement of actuating connector lever, thus machine does not start.

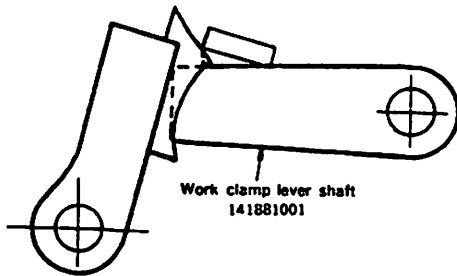

During the machine's operation, claw prevents the movement of work clamp connecting lever, thus work clamp does not lift up.

## CHAPTER II ADJUSTMENT

### 1. Adjustment on needle bar and shuttle hook mechanism

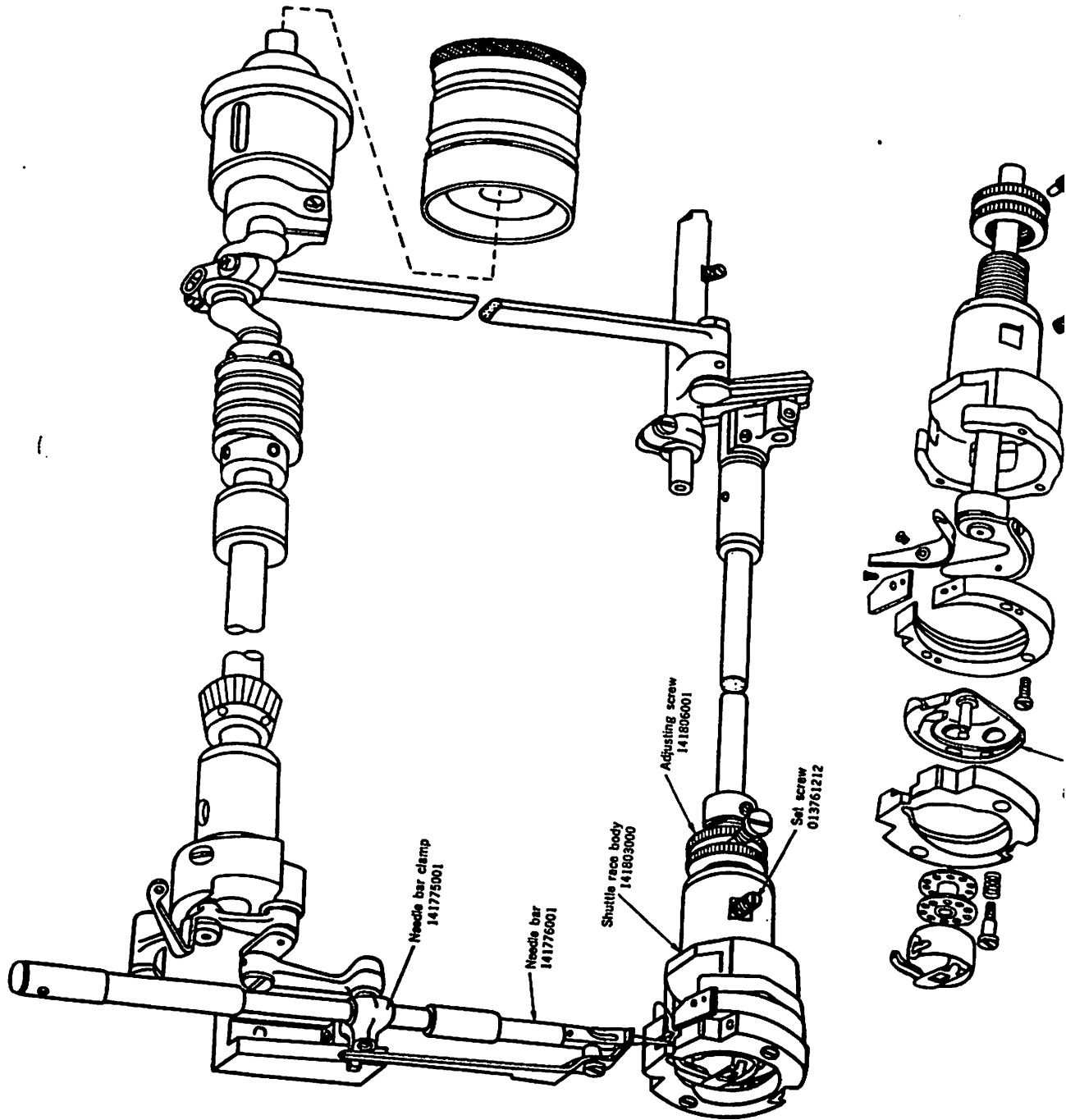

**(1) Setting shuttle race body (clearance between hook and shuttle drive spring)**

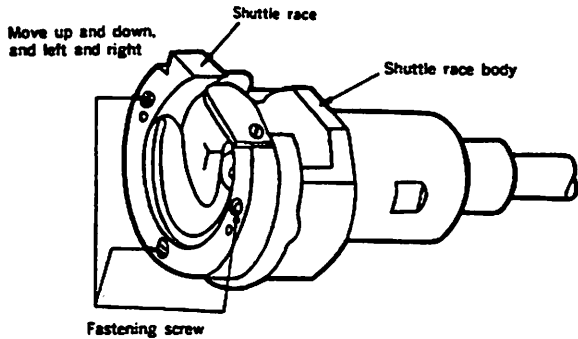

When setting shuttle race body, adjust the position of shuttle race by setting three screws so that the clearance between hook point and point of shuttle driver spring may be 0.3 - 0.5mm both up and down positions.

**(NOTE)** In this case, remove needle from needle bar.

This assembling is rigidly done when shipping, thus be sure not to remove shuttle race body except unavoidable necessity.

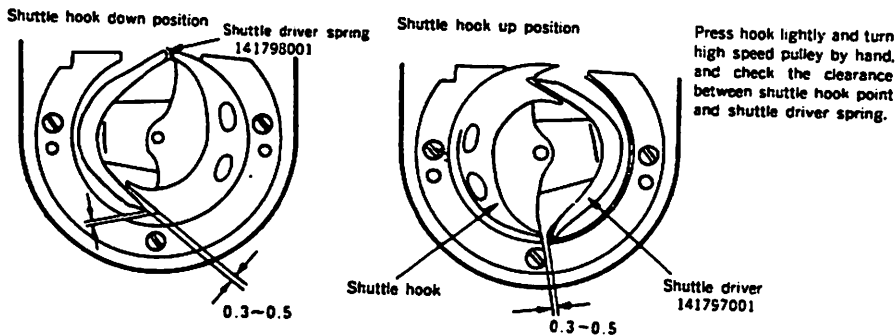

**(2) Adjusting lower shaft play**

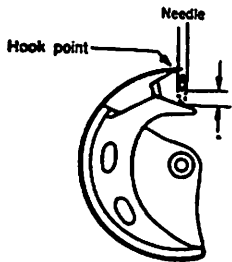

When setting shuttle driver, firstly fasten the silver screw matching with the groove of lower shaft, then black screw. And, set collar not to have play of lower shaft.

**(NOTE)** In order to adjust easily the position of slide block holder and height of needle bar, the groove of lower shaft is correspondent to the diameter of silver screw, therefore, please make sure to follow the above instruction.

### (3) Adjusting hook and needle timing

Loosen slightly two screws on shuttle driver and when needle bar is raised to lowest position, adjust the position of shuttle driver so that shuttle hook is in line with the centre axis of needle, then fasten tightly the screws.

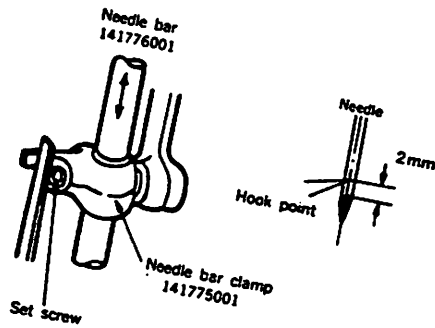

### (4) Adjusting lower shaft play

When shuttle hook point is in line with the centre axis of needle, adjust the height of the needle bar connecting stud screw so that the needle eye is positioned at 2mm from the hook point.

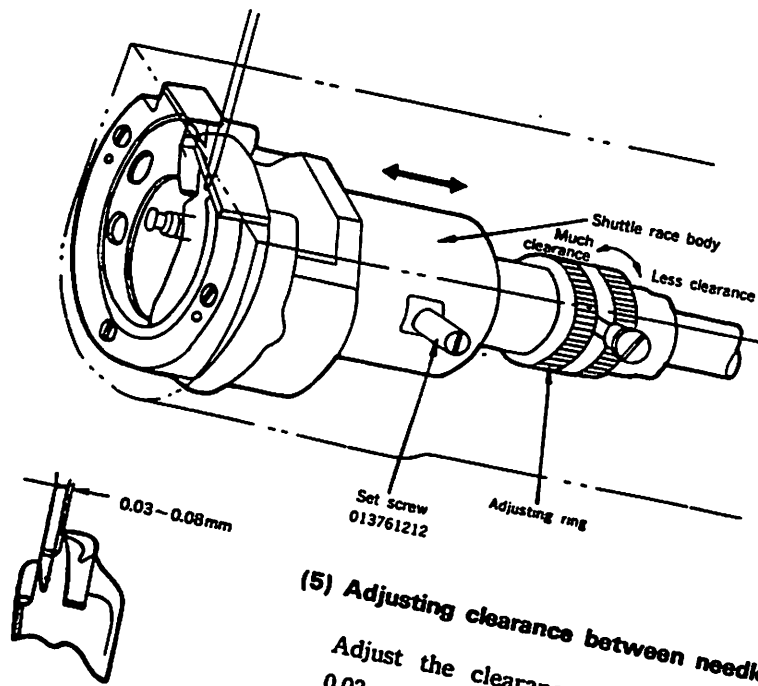

### (5) Adjusting clearance between needle and hook point

Adjust the clearance between needle and hook point to be 0.03mm~0.08mm by loosening set screw and rotate adjusting ring. After completion, fasten securely.



## 2. Adjustment on feed mechanism

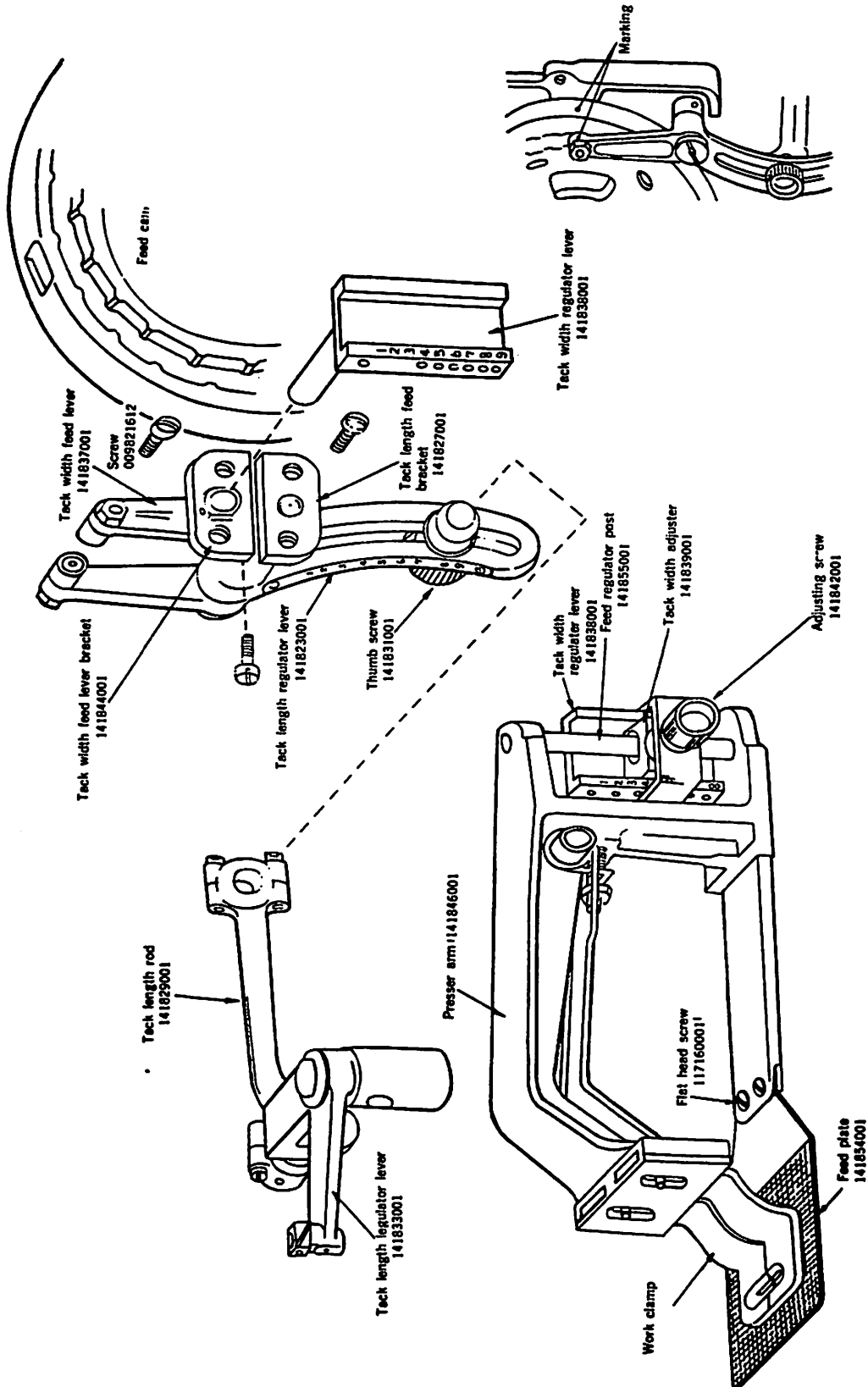

Bar tacks will be made as the power is transmitted to tack length and tack width mechanisms with the outer and inner grooves of feed cam. The tack design must be made within the rectangular opening in work clamp and even when their swings are regulated by feed adjustment, the positions of their centre swings must be always at the same point.

**(1) Adjusting timing of needle and feed cam**

Feeding begins as the needle raises out of the material and finishes before needle comes down into the materials. If adjustment is required, loosen worm wheel shaft nut and set bolts and turn feed cam by degrees.

Turning feed cam in its rotating direction, it advances the timing of needle and feed cam and vice versa.

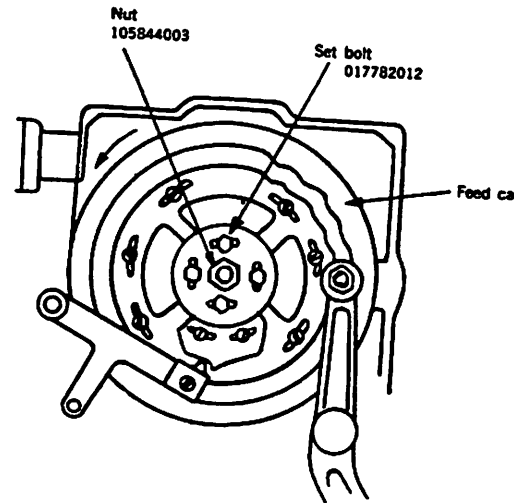

**(2) Adjusting tack width movement**

Adjusting tack width and tack length movements require very sensible and precise cautions. Make adjustment firstly on tack width movement and secondly tack length with great care. Once the correct adjustment was made, no further adjustment is required unless absolutely needed. First of all, adjust to get correct position between work clamp and feed plate by loosening set bolt.

- 1) Let the first needle come down into the needle hole.
- 2) Match the opening on feed plate and work clamp. In case that openings are in disorder, loosen flat head screws on feed plate and get correct position and fasten flat head screws.
- 3) Loosen adjusting screw and raise hinge block shaft until hinge block shaft is in level with tack width regulator lever shaft and tighten adjusting screw.
- 4) Loosen feed bracket, fastening screw, and move presser arm. Then, set the position of bracket so that the needle hole is positioned exactly at the centre of work clamp, and then tighten fastening screw.
- 5) Loosen tack width lever fastening screw and lower hinge block all the way down, then tighten fastening screw. Again, move presser arm and set presser arm so that the needle hole will be positioned exactly at the centre of work clamp, then tighten fastening screw.

### (3) Adjusting tack length movement

- 1) Raise clutch and turn driving pulley by hand until the needle comes down into the needle hole with tack length regulator in the marked position of the rim of feed cam.
- 2) Loosen feed bracket fastening screw, when tack length regulator rod brings to its fullest extent in the elongated hole of tack length regulator lever, set the position of bracket not so as to move work clamp.
- 3) Loosen ball stud and set the position of presser arm so that the needle will be positioned at the centre of work clamp.

### 3. Adjustment on clutch mechanism

Unless this mechanism is in order, the machine will not stop properly. much more power may be consumed for the machine's operation, or machine's durability may be considerably lessened.

In case of adjustment, please follow the instructions.

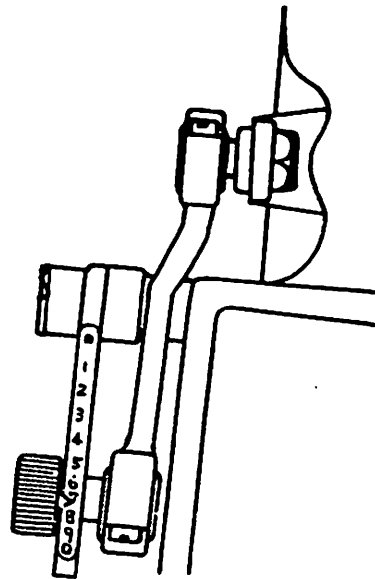

#### 1) Clutch lever catch and clutch stop latch

Adjust the position of clutch stop latch so that the minimum distance between stop cam and clutch stopper is about 3mm.

(NOTE) Insert 3mm thickness board there to enable easy adjustment and make sure that brake shoe is apart from stop cam rid.

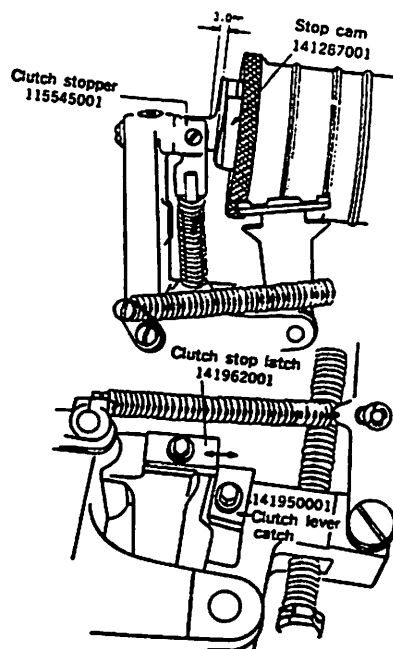

## 2) Adjusting belt shifter

Remove two belts when you do the adjustment.

(1) At the position of tripping dog being over stop cam, adjust the level of belt shifter so that the belts are at idle pulley and slow speed pulley.

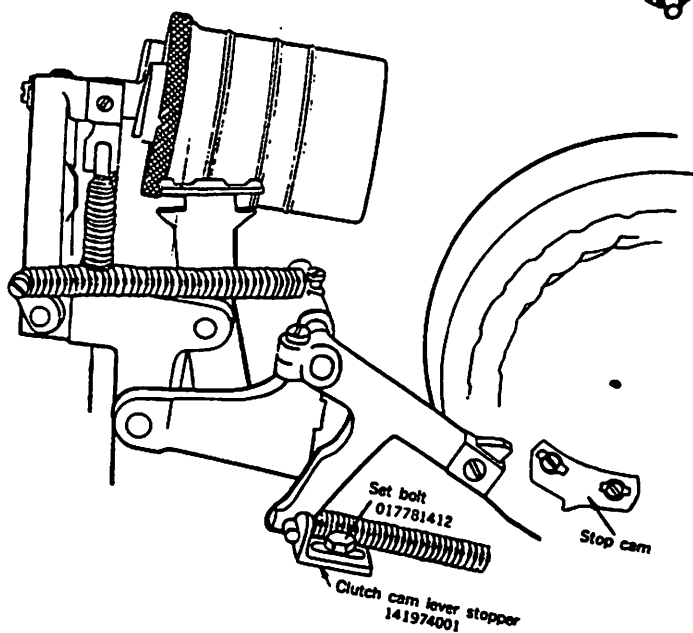
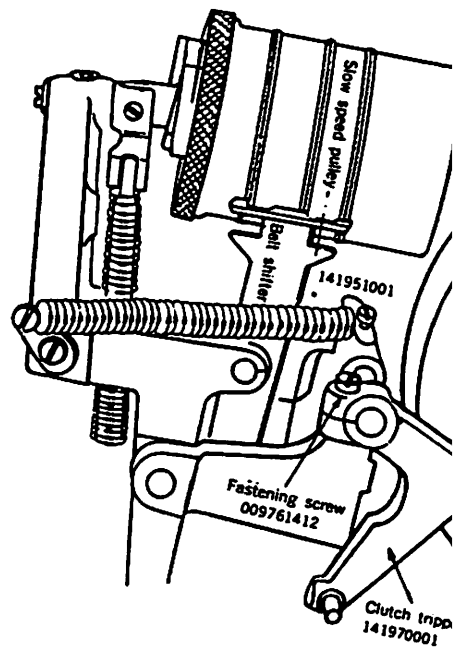

(2) At the position of tripping dog being out of stop cam, adjust the position of stopper so that the belts are at idle pulley and high speed pulley.

(3) Adjusting height of tripping dog

Please adjust the position of lever so that clutch may come into function when tripping dog reaches three quarter position of stop cam.

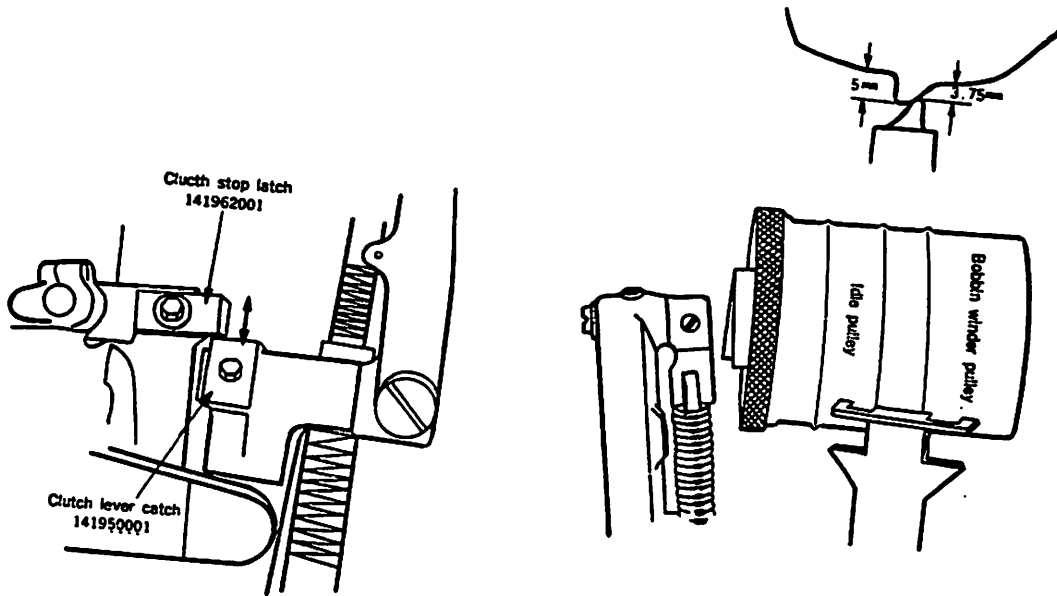

### 3) Adjusting stop position

(1) Timing of stop cam and clutch stopper

Please adjust stop cam so that clutch stop latch may disengage with clutch lever catch one stitch before the end of sewing cycle. In this case, please see that clutch stop latch will disengage with clutch lever catch within  $\pm 30^\circ$  from the position where the groove of stop cam falls into line with clutch stopper. In case of adjustment, loosen two set screws and move stop cam left or right to adjust. At that time, make sure to get proper timing by turning high speed pulley by hand.

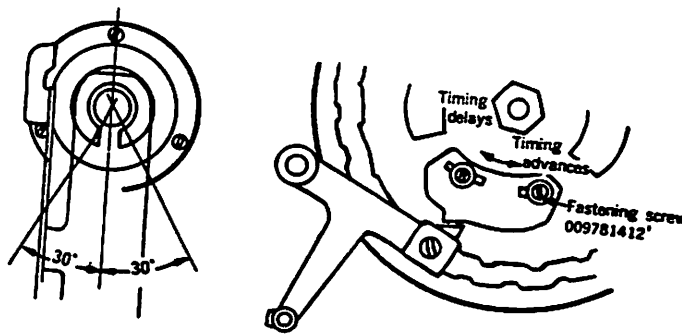

**(2) Position of emergency stop lever**

When tripping dog is at the highest position of stop cam, adjust by loosening fastening screw so that the distance between the arm hole and emergency stop lever is about 1 mm.

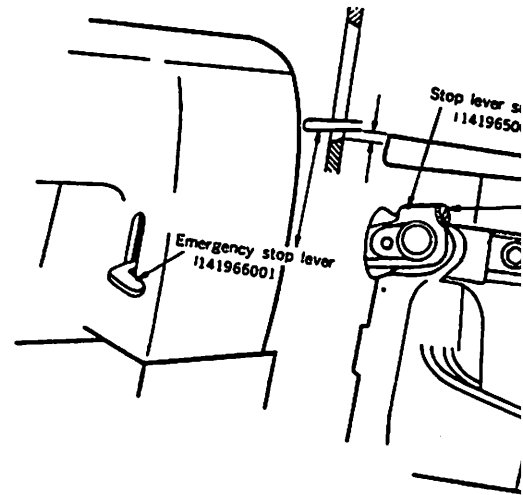

**4) Pressure of clutch lever spring**

Adjust clutch lever spring so that it will get enough tension to permit clutch stopper to fit positively into the groove of stop cam to stop the machine gently. In case of adjustment, loosen fastening screw and change the angle of spring adjusting plate.

**5) Pressure of stopper spring A**

If stopper spring is too weak in tension, needle may come down into the material as the machine is going to stop at wrong position.

If, on the other hand, stopper spring is too strong in tension, the impact exerted on the machine at the time to stop will be increased and this will adversely affect the durability of the machine. Adjust the tension of stopper spring by turning nuts. For your guidance, the proper tension of stopper spring is measured 10-12 mm distance from nut to end of stopper adjusting spring shaft.

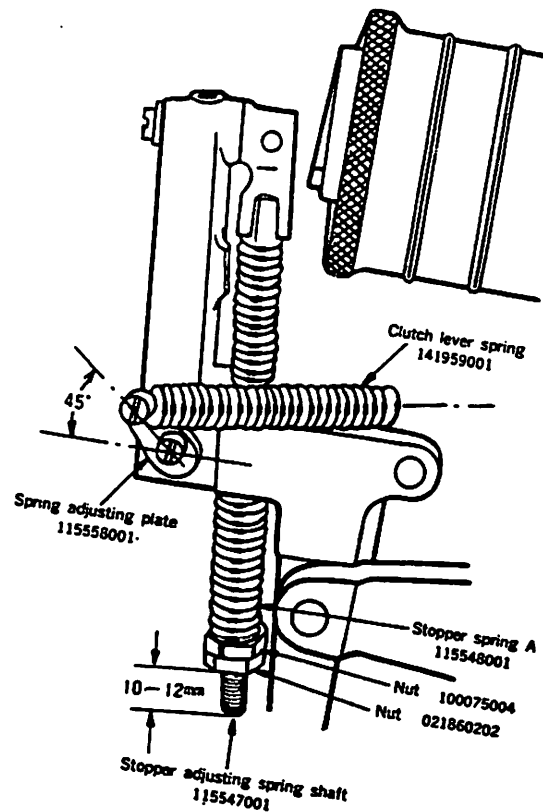

#### 4. Adjustment on work clamp mechanism

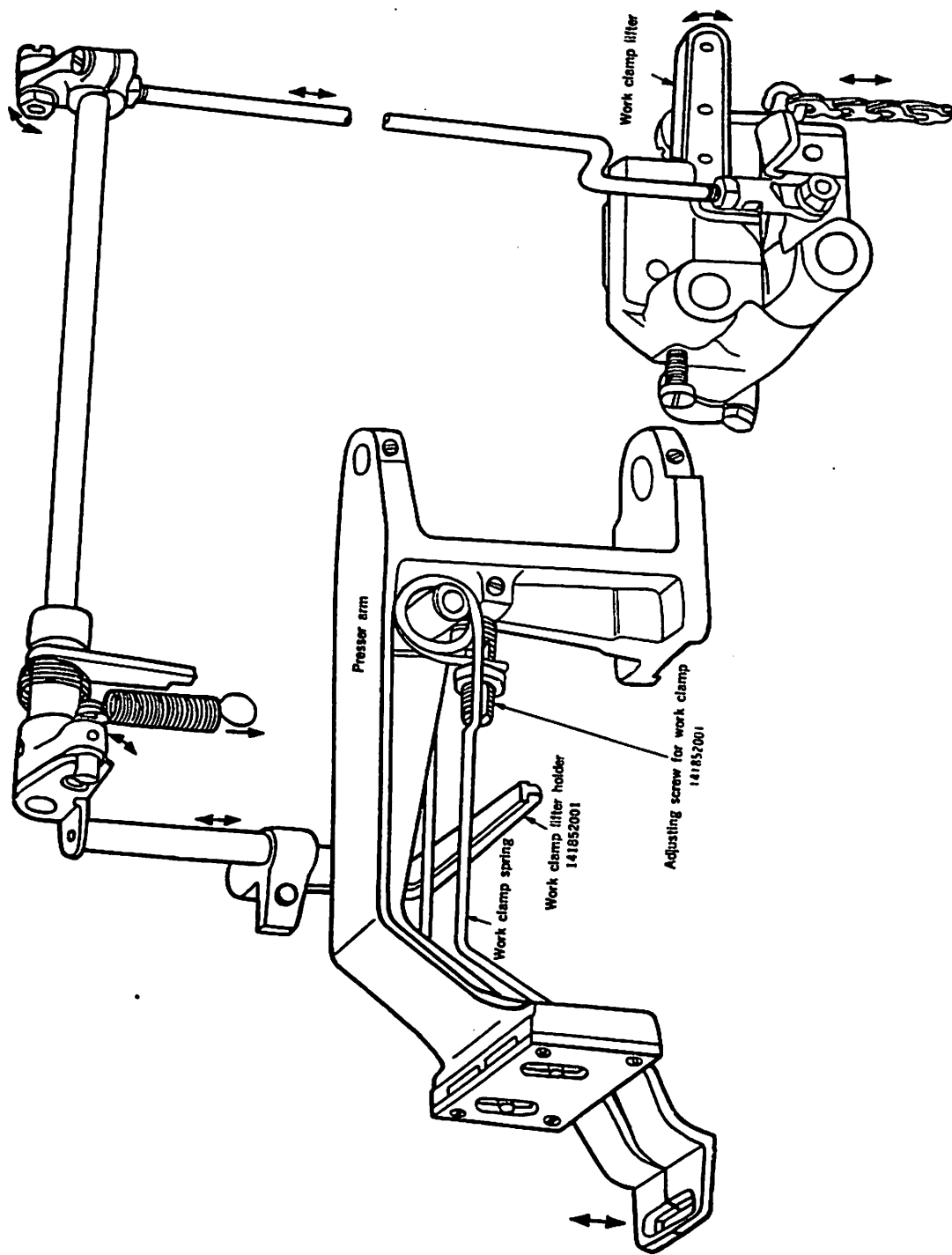

**1) Position of presser arm**

Adjust the height of presser arm to be 2.5~3.0mm between presser arm and presser spring by set screw.

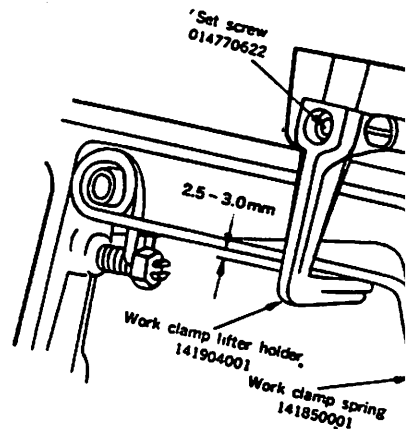

**2) Adjusting work clamp lifting lever**

When the left treadle is depressed upto stopper, adjust the height of work clamp to be 10mm apart from feed plate.

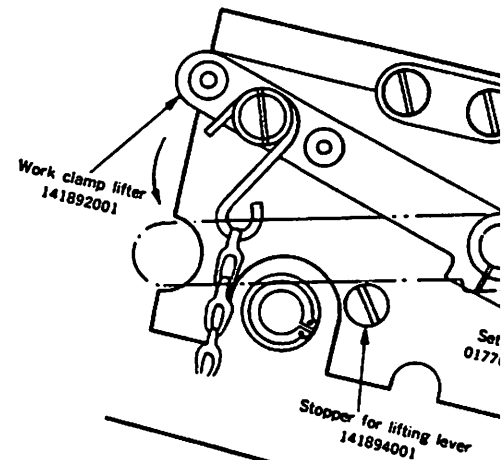

**3) Adjusting pressure of work clamp**

Strong pressure on thick materials and weak pressure on thin materials are required and reasonable pressure is required to prevent the materials from slippage.

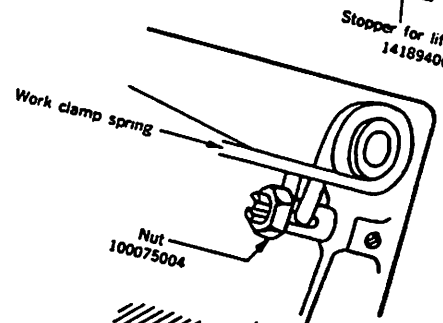

**4) Position of thread retainer**

When work clamp is lifted up, thread retainer is required to play a role of thread wiper. In case of adjustment, change the angle of thread retainer by moving thread retainer set plate (A) up and down.

(NOTE) In case that thread retainer wipes the upper thread, make sure that it does not hit the needle, even by manual operation.

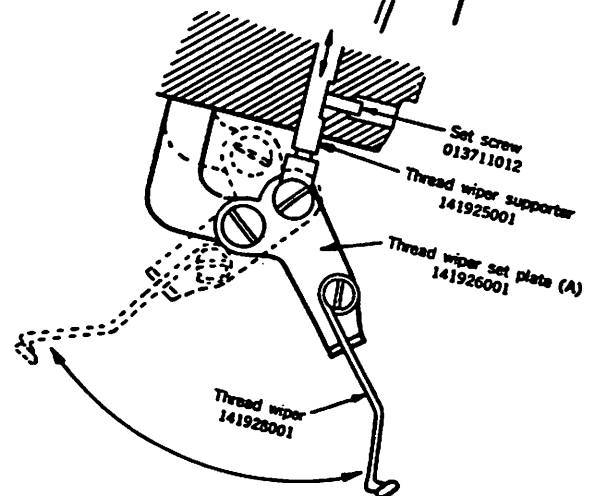



## 5. Adjustment on thread trimming mechanism

The upper thread knife, lower thread knife and thread retainer are mounted with pinion stud bracket and are operated by the power transmitted from knife cam.

- 1) As the needle rises out of the needle hole after the first stitch, thread retainer catches the upper thread to prevent the upper thread from slipping out of the needle eye.
- 2) Thread retainer releases the thread just before the fifth stitch is formed.
- 3) As soon as the upper thread is pulled up by thread take-up lever, lower thread knife catches the lower thread. At this moment, the point of upper thread knife is just in front of the needle hole of needle plate.
- 4) Upper thread knife enters into the upper thread loop while the hook point comes to its downmost position after catching the loop in the process of forming the final stitch.
- 5) The machine stops.
- 6) When the left treadle is depressed, connecting rod adjuster disengages from the tip of knife bar and connecting rod spring pulls the knives to trim both threads.

(NOTE) In adjusting the knives, firstly remove needle plate and make sure the knives are installed correctly. Then, make adjustment in the following order.

i) Setting order on knives and thread retainer

ii) Relative measurement between thread retainer and knives

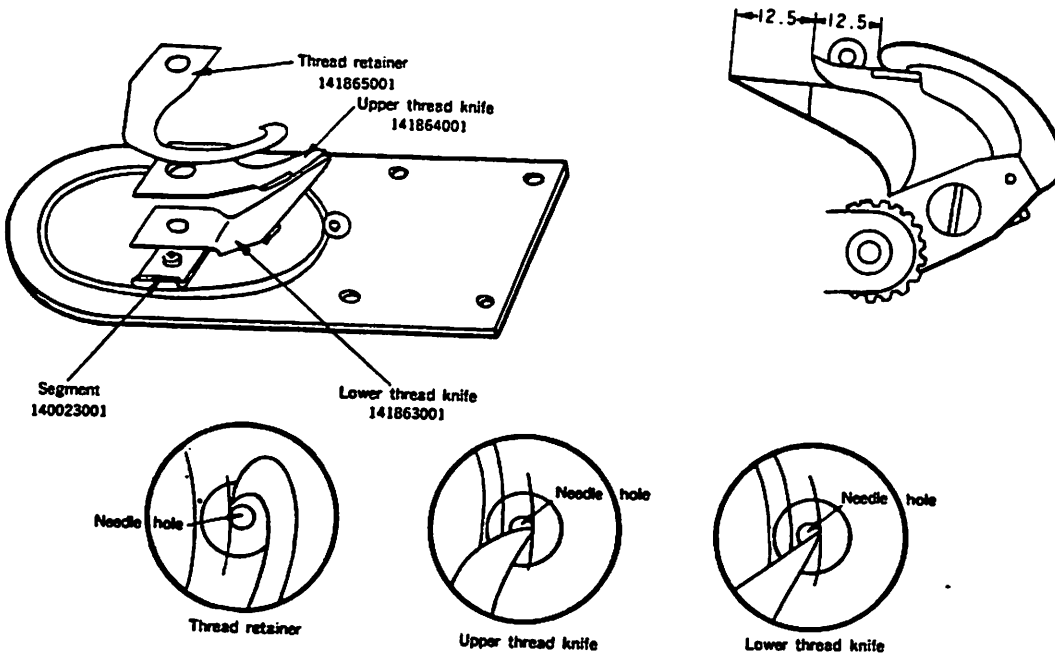

ii) Relation between needle hole and thread retainer and knives

### 1) Adjusting bite between segment and rack

When you set needle plate, meet timing marks on segment and rack. After setting, adjust the bite between segment and rack checking the play of top point of thread knives to be less than 0.5mm by turning two fastening screws even though rack is positioned at either forward or backward.

(NOTE) In case of tight bite between segment and rack, the movement of knife bar will not be smooth, thus it causes that needle hits knives or thread retainer or it causes wrong thread trimming.

Therefore, adjust the bite to get slight play.

### 2) Adjusting position of knives and timing of thread trimming

#### (1) Setting position of rack

At thread trimming lever roller is just above the recess portion of knife cam, that is the second stitch, and at the stop position of thread trimming knives, the point of lower thread knife is positioned at the red mark of needle plate.

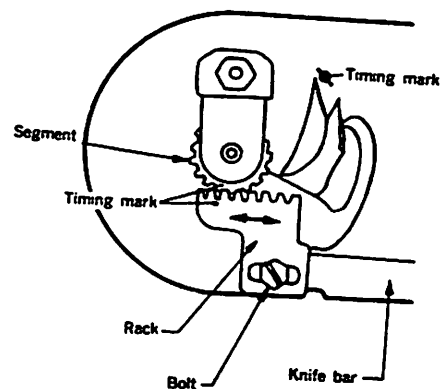
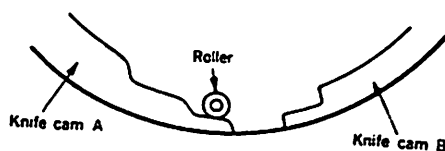
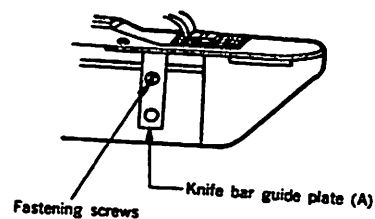

#### (2) Adjusting timing of knife cam A and B

##### (i) Knife cam A

Raise clutch and turn driving pulley by hand and get roller positioned at each hand and get roller positioned at each three rising points of knife cam A, and check needle will not touch with thread trimming knives and the upper thread loop will not touch with knives. In case of adjustment, loosen fastening screw for knife cam A and adjust the timing by moving left or right.

##### (ii) At one stitch before the final stitch,

when stud screw thread take-up lever is positioned within the distance of 5mm from its highest position, adjust the position of knife cam B so that stud screw is stepped

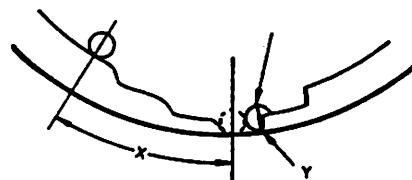

### 1) Adjusting bite between segment and rack

When you set needle plate, meet timing marks on segment and rack. After setting, adjust the bite between segment and rack checking the play of top point of thread knives to be less than 0.5mm by turning two fastening screws even though rack is positioned at either forward or backward.

(NOTE) In case of tight bite between segment and rack, the movement of knife bar will not be smooth, thus it causes that needle hits knives or thread retainer at either forward or backward. Therefore, adjust the bite to get slight play.

### 2) Adjusting position of knives and timing of thread trimming

#### (1) Setting position of rack

At thread trimming lever roller is just above the recess portion of knife cam, that is the second stitch, and at the stop position of thread trimming knives, the point of lower thread knife is positioned at the red mark of needle plate.

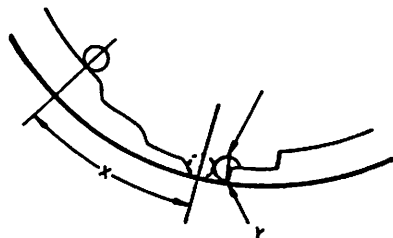
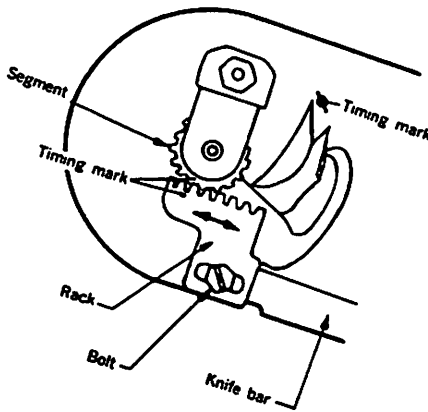
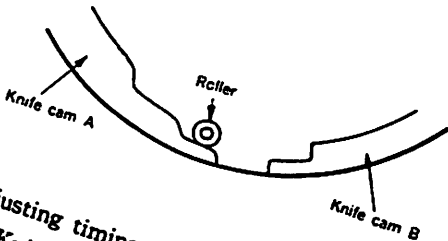
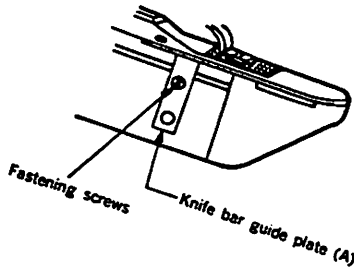

Adjusting timing of knife cam A and B

1) Knife cam A

Raise clutch and turn driving pulley by hand and get roller positioned at each three rising points of knife cam A, and the upper thread knives will not touch with thread. In case of adjustment, loosen fastening screws of knife cam A and adjust the position of knife cam A by moving left or right.

2) Knife cam B

When the thread take-up lever is positioned within the distance of 5mm from the stud screw, adjust the position of knife cam B so that stud screw is stepped

### 1) Adjusting bite between segment and rack

When you set needle plate, meet timing marks on segment and rack. After bite between segment and rack checking the play of top point of thread knife 0.5mm by turning two fastening screws even though rack is positioned backward.

(NOTE) In case of tight bite between segment and rack, the movement of rack will be smooth, thus it causes that needle hits knives or thread retainer. Therefore, adjust the bite to get slight play.

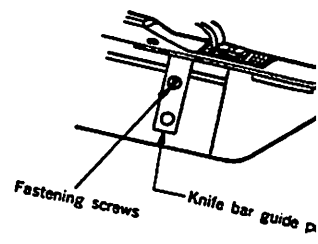

### 2) Adjusting position of knives and timing of thread trimming

#### (1) Setting position of rack

At thread trimming lever roller is just above the recess portion of knife cam, that is the second stitch, and at the stop position of thread trimming knives, the point of lower thread knife is positioned at the red mark of needle plate.

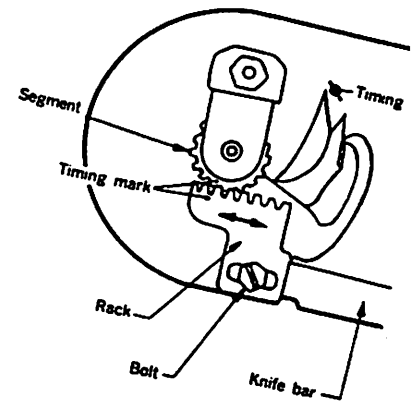
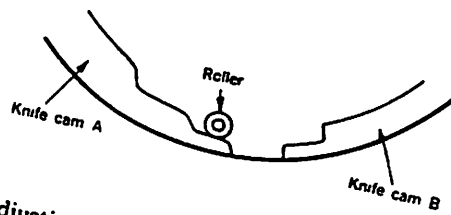

#### (2) Adjusting timing of knife cam A and B

##### (i) Knife cam A

Raise clutch and turn driving pulley by hand and get roller positioned at each three rising points of knife cam A, and check needle will not touch with thread trimming knives and the upper thread loop will not touch with knives. In case of adjustment, loosen fastening screw for knife cam A and adjust the timing by moving left or right.

##### (ii) Knife cam B

At one stitch before the final stitch, when stud screw thread take-up lever is positioned within the distance of 5mm from its highest position, adjust the position of knife cam B so that stud screw is stepped

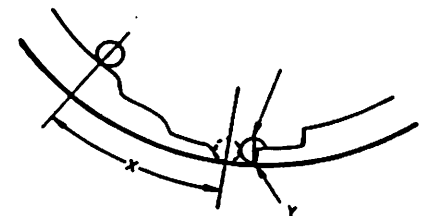

down at the first recess portion of knife cam B. This is the timing that lower thread knife hooks lower thread.

(iii) Knife cam B

At the final stitch, adjust the position of knife cam B by loosening fastening screw so that upper thread knife may hook the upper thread loop during hook point travelling down in the range of 90°~135° with upper thread loop.

(NOTE) When roller is located in the range of X as per illustration, please make sure that the needle will not hit the upper thread knife. And, at Y position of stud screw, at the final stitch, while hook point travels with upper thread loop down in the range of 90°~135°, make sure that stud screw will step down at the second recess portion of knife cam B.

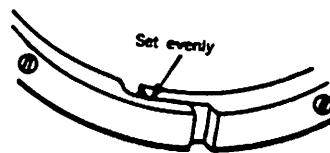
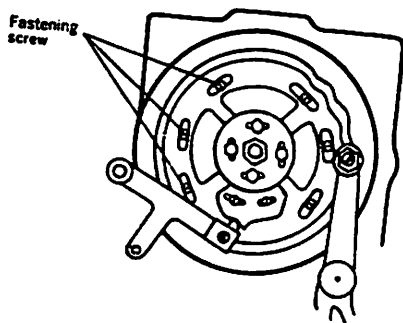

(NOTE) In case that you may rotate knife cams, set these cams evenly on the top not so as to cause unusual noise.

3) Position of thread trimming lever plate

At the stop position, loosen two set screws and adjust thread trimming adjusting screw so that the point of lower thread knife will be positioned at the red mark on needle plate.

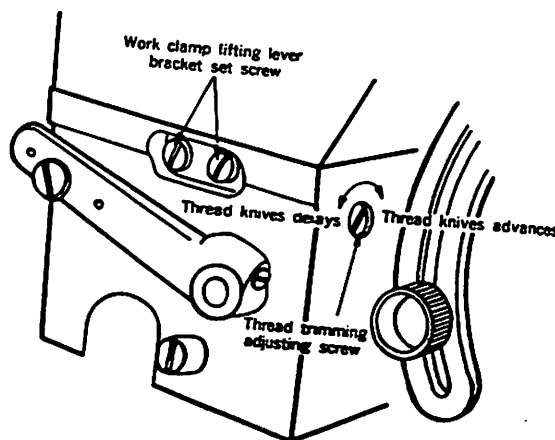

4) Adjusting thread trimming stopper screw

When work clamp is lifted up, adjust by stopper screw so that thread trimming lever roller may be apart about 0.3mm from the bottom of knife cam.

At this moment, the needle hole of needle plate is positioned at the rear of upper thread knife.

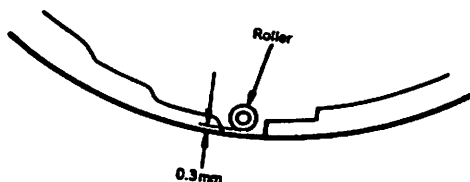

**2) Adjusting tension of knife bar pulling spring**

If knife bar pulling spring has too weak tension, knives often fail to trim the threads and in some extreme cases, collide with needle causing breakage. If, on the other hand, spring has too strong tension, extra power is required to drive the knives, thus the machine does not work smoothly. To adjust the spring tension, loosen set screw and move spring adjusting bar left or right.

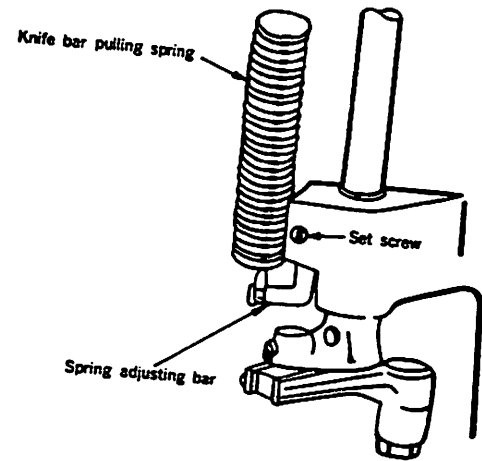
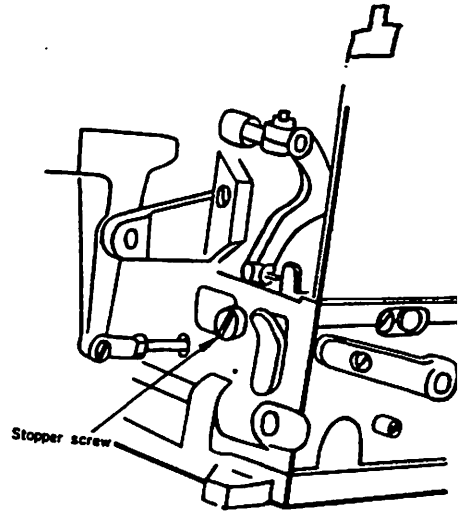

## 6. Adjustment on safety mechanism

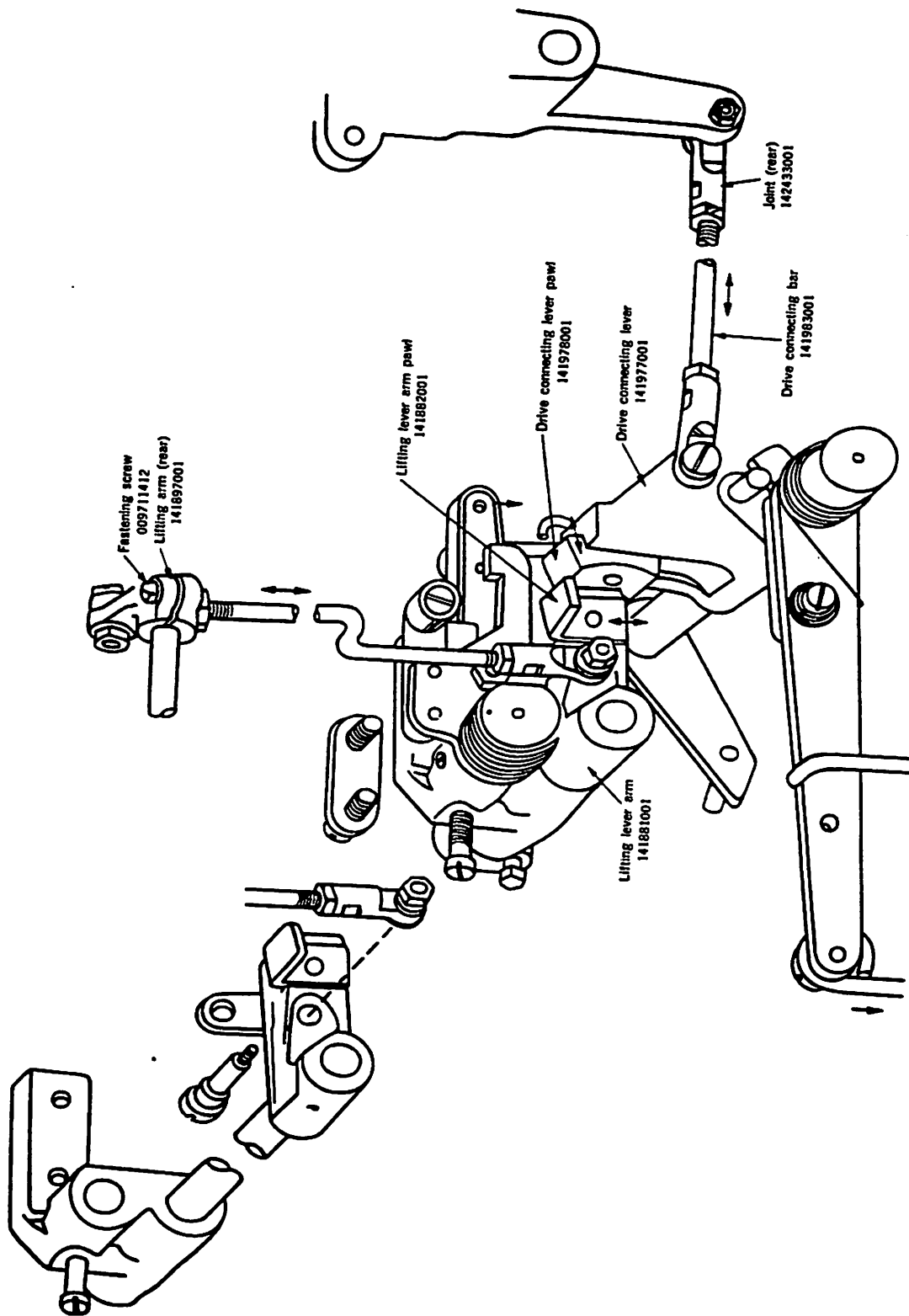

While the machine is in operation, work clamp stays down even if the right treadle depressed and also thread trimming lever remains inoperative. When the left treadle after the machine has automatically stopped, thread trimming lever is actuated to up and then work clamp is lifted up.

In case of adjustment, please follow the instructions.

**(1) Adjusting height of lifting lever arm pawl**

Set the height of lifting lever arm pawl so as to be in line with lifting lever arm.

**(2) Adjusting drive connecting bar**

At the stop position, when the left treadle is depressed, adjust eccentric screw of joint ( ) that drive connecting lever pawl may contact with lifting lever arm pawl. This can be firm with elimination of the clutch lever play. In case that the adjustment is not possible by this method, adjust the length of drive connecting bar by turning point (rear) and adjust contact between drive connecting lever pawl and lifting arm lever pawl.

(NOTE) After the adjustment is completed, check the movement of work clamp lifting lever. be smooth operation and the smaller the clearance, the smoother the operation.

**(3) In the machine's operation, adjust by lifting arm (rear) the clearance to be smallest between drive connecting lever pawl and lifting arm lever pawl.**

**(4) Just before the machine stops, make sure that the lifting arm lever pawl will be disengaged with drive connecting lever pawl and thread trimming mechanisms will be functioned. If incomplete, repeat the adjustment explained above.**

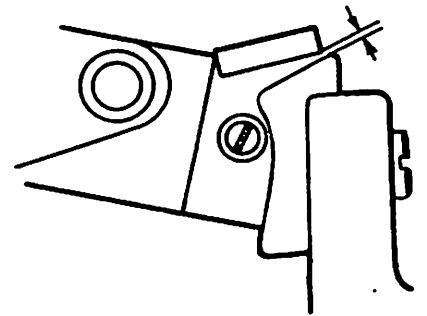



## 7. Adjustment on thread nipper mechanism

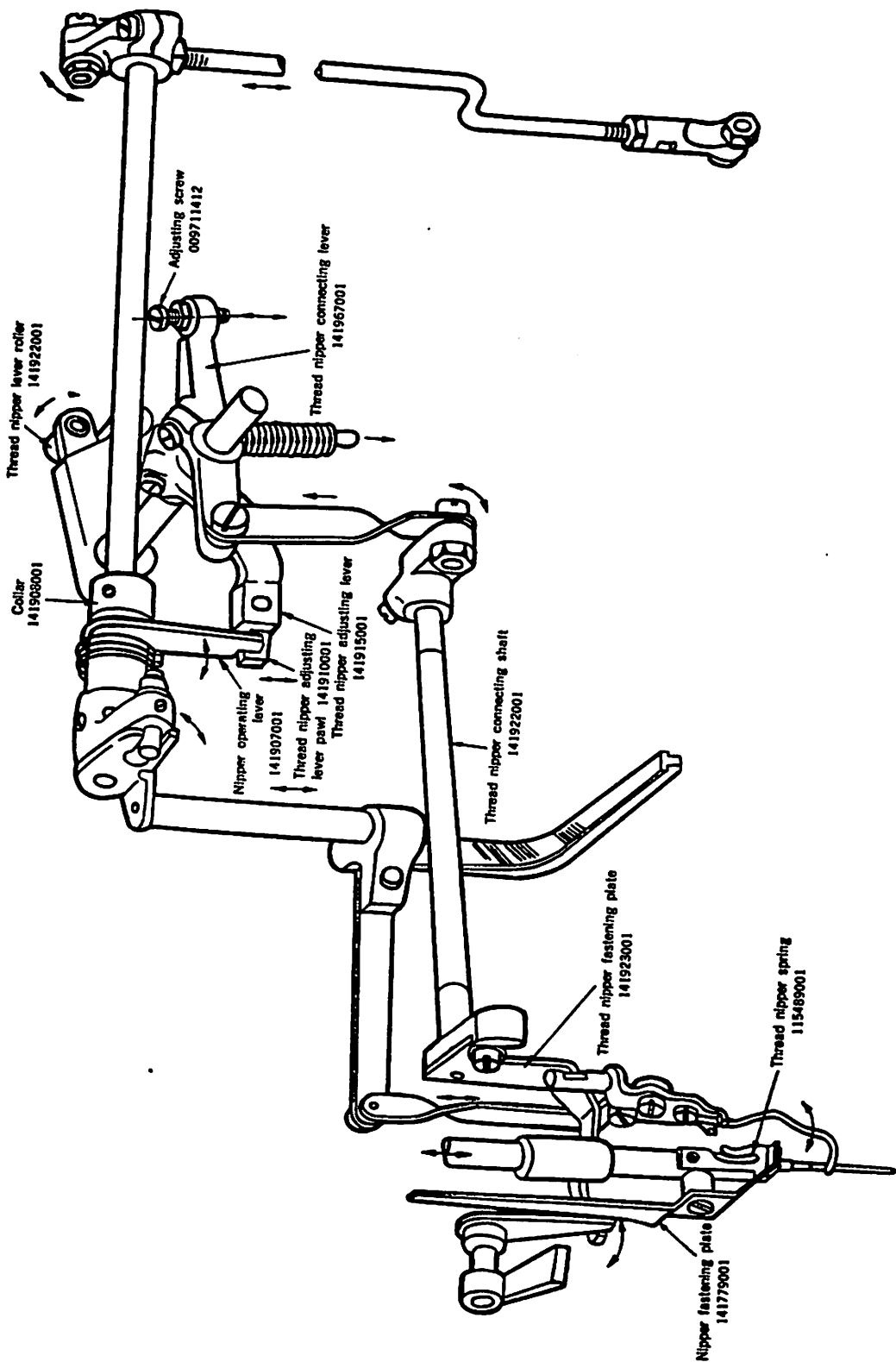

3 needle begins to raise for the final stitch, the upper thread knife enters into loop. And the main tension is released to allow sufficient length of the thread. When the left treadle is depressed, it works the thread nipper mechanism and a thread nipper spring on needle bar is lightly tightened to prevent the thread from needle eye and being jammed. Before the needle comes down for the second stitch, nipper is released and main tension is tightened. Make adjustments, if necessary in the following manners.

**1) Position of thread nipper lever roller**

At the stop position, adjust roller position so that its centre will be matched with red marking.

**2) Position of thread nipper connecting lever**

At the position of roller being over the recess portion of feed cam, the end of tension release guide pin must be positioned at the upper line of feed cam. In case of adjustment, loosen fastening screw and rotate thread nipper connecting shaft.

**3) Position of thread nipper adjusting lever**

At the stop position (before lifting work clamp), the end of tension release guide pin must be positioned at the lower line of feed cam on the condition that thread nipper operating lever contacts thread nipper adjusting lever pawl.

In case of adjustment, loosen thread nipper adjusting lever screw, fix the position of thread nipper connecting shaft and adjust to bite thread nipper adjusting lever pawl and nipper operating lever, then fasten screw tightly. (At that time, the position of roller is 2mm apart from recess portion of feed cam).

At this position, when nipper operating lever is disengaged, adjust roller to move smoothly to the bottom of the recess portion of feed cam.

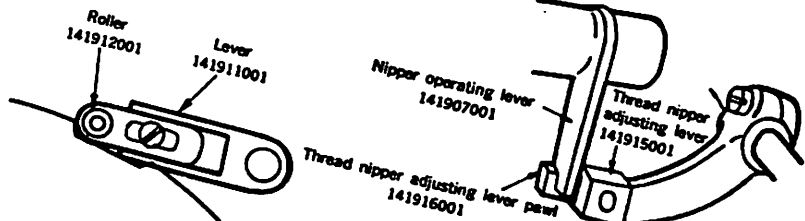
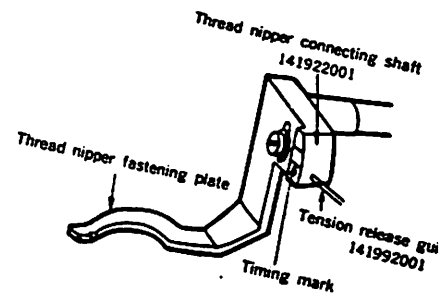
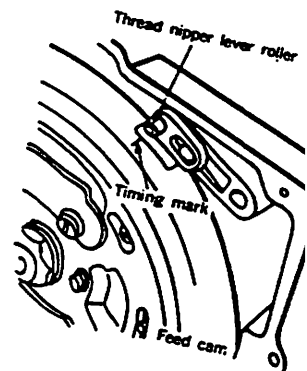

#### 4) Adjusting main tension regulator

At the position of roller being over the recess portion of feed cam, adjust tension adjusting thumb screw so that main tension will be tightened and at the position of roller being in the recess portion of feed cam, adjust it so that main tension will be loosened.

#### 5) Position of nipper fastening plate

At the position of thread nipper adjusting lever pawl being disengaged with nipper operating lever, adjust thread nipper fastening plate moving left or right so that thread nipper spring on needle bar may catch the upper thread securely.

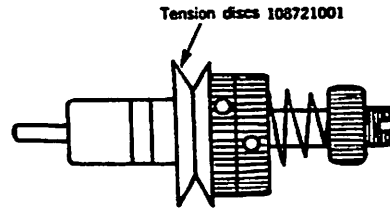

#### 6) Adjusting collar for nipper operating lever

At the stop position, when the left treadle is depressed, adjust the bite between thread nipper adjusting lever pawl and nipper operating lever by positioning collar for nipper operating lever.

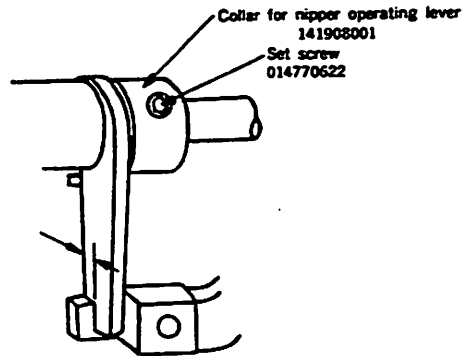

## Adjustment on drive mechanism

### 1) Adjusting clutch actuating lever

In case that the right treadle is depressed strongly, it causes the belts slipping off on pulleys due to too much movement of the clutch. In order to avoid this, adjust following manners.

- (1) Put set screw contained in the accessory box into the fixing screw hole.
- (2) Raise the clutch and pull down drive connector until drive lever shaft will contact with set pin and fix drive lever shaft by set screw as explained above.
- (3) Set the machine head in normal position and loosen set screw and adjust to get 3mm distance between bed and the lower part of clutch actuating lever by lowering the lever, then fasten set screw.

After completion, loosen set screw as explained in (2). (Take out set screw when machine is in operation)

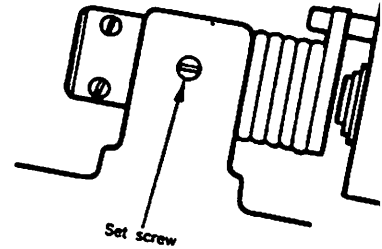

### 2) Adjusting clutch actuating lever stopper

In order to prevent the right treadle from going upward, clutch actuating lever stopper is limited the movement of clutch actuating lever.

In case of adjustment, adjust in the following manners.

- (1) Be the machine at stop position.
- (2) Fix actuating lever shaft with set screw contained in the accessory box.
- (3) Set the machine in normal position.
- (4) Adjust the height of stopper to be 1mm distance by loosening nut.
- (5) After completion, take out set screw.

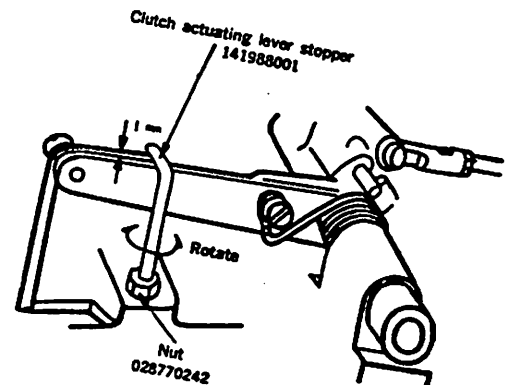
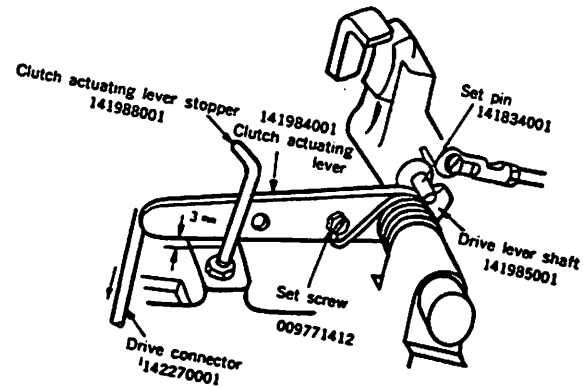

## Adjustment on drive mechanism

### 1) Adjusting clutch actuating lever

In case that the right treadle is depressed strongly, it causes the belts slipping pulleys due to too much movement of the clutch. In order to avoid this, following manners.

- (1) Put set screw contained in the accessory box into the fixing screw hole.
  - (2) Raise the clutch and pull down drive connector until drive lever shaft will contact with set pin and fix drive lever shaft by set screw as explained above.
  - (3) Set the machine head in normal position and loosen set screw and adjust to get 3mm distance between bed and the lower part of clutch actuating lever by lowering the lever, then fasten set screw.
- After completion, loosen set screw as explained in (2). (Take out set screw when machine is in operation)

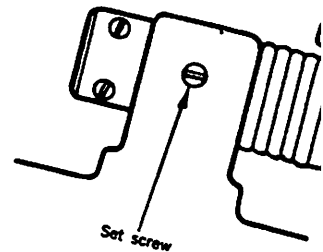

### 2) Adjusting clutch actuating lever stopper

In order to prevent the right treadle from going upward, clutch actuating lever stopper is limited the movement of clutch actuating lever.

- In case of adjustment, adjust in the following manners.
- (1) Be the machine at stop position.
  - (2) Fix actuating lever shaft with set screw contained in the accessory box.
  - (3) Set the machine in normal position.
  - (4) Adjust the height of stopper to be 1mm distance by loosening nut.
  - (5) After completion, take out set screw.

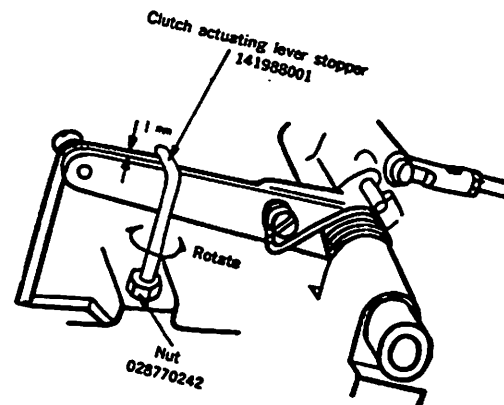
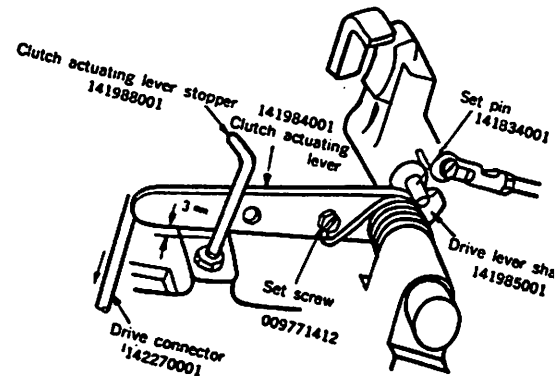

## Adjustment on drive mechanism

### 1) Adjusting clutch actuating lever

In case that the right treadle is depressed strongly, it causes the belts slipping on pulleys due to too much movement of the clutch. In order to avoid this following manners.

- (1) Put set screw contained in the accessory box into the fixing screw hole.
  - (2) Raise the clutch and pull down drive connector until drive lever shaft will contact with set pin and fix drive lever shaft by set screw as explained above.
  - (3) Set the machine head in normal position and loosen set screw and adjust to get 3mm distance between bed and the lower part of clutch actuating lever by lowering the lever, then fasten set screw.
- After completion, loosen set screw as explained in (2). (Take out set screw when machine is in operation)

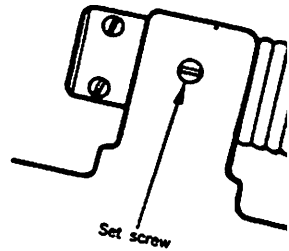

### 2) Adjusting clutch actuating lever stopper

In order to prevent the right treadle from going upward, clutch actuating lever stopper is limited the movement of clutch actuating lever.

- In case of adjustment, adjust in the following manners.
- (1) Be the machine at stop position.
  - (2) Fix actuating lever shaft with set screw contained in the accessory box.
  - (3) Set the machine in normal position.
  - (4) Adjust the height of stopper to be 1mm distance by loosening nut.
  - (5) After completion, take out set screw.

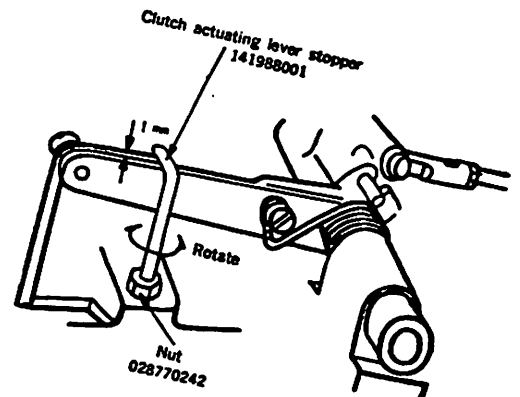
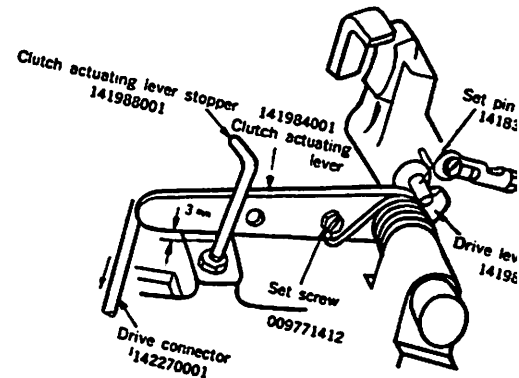

## 9. Adjustment on bobbin winder mechanism

### 1) Adjusting height of bobbin winder tension

In case of uneven winding on bobbin, loosen tension stud collar set screws and adjust the position of bobbin winder tension by raising or lowering tension stud collar.

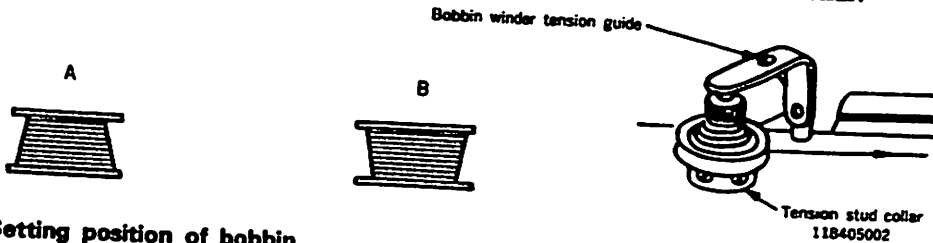

### 2) Setting position of bobbin presser

When bobbin presser contacts with bobbin winder shaft, adjust the position of bobbin winder pawl so that the top end of spring plate may be positioned at the centre of bobbin winder pawl.

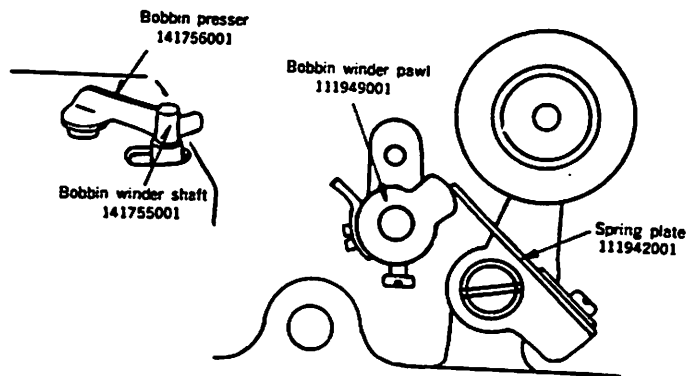

### 3) Setting position of bobbin presser stopper

When spring plate is disengaged with bobbin winder pawl, set the position of bobbin presser stopper so that rubber ring may contact with pin and bobbin presser may not have too much play.

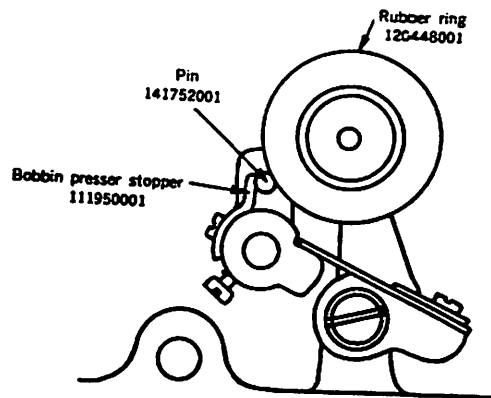

## CHAPTER III TROUBLE SHOOTING

### 1. Thread tension mechanism

#### 1) Thread-off at the beginning

- (1) **CAUSE:** In case of loose tension on thread nipper spring on needle bar.  
**ADJUSTMENT:** Refer 7, Adjustment on thread nipper mechanism.  
Page 30.
- (2) **CAUSE:** In case of wrong positioning of thread retainer.  
**ADJUSTMENT:** Set thread retainer to catch the upper thread at the first stitch. The position of thread retainer is referred to 5. Adjustment on thread trimming mechanism.  
Page 22.
- (3) **CAUSE:** In case of short thread end after trimming.  
**ADJUSTMENT:** At the final stitch, set the timing of tension release, theread nipper spring on needle bar, and functioning of knives.

#### 2) Thread breakage at the machine's stop

- CAUSE:** In case of not being loosen on main tension regulator at the final stitch.  
**ADJUSTMENT:** Adjust main tension regulator so as to be loosen at the final stitch so that the proper length of thread is pulled by upper thread knife.

#### 3) Untidy length of thread end from needle

- CAUSE:** In case of the upper thread being trimmed by knife before tightening the upper thread by thread nipper spring on needle bar.  
**ADJUSTMENT:** Adjust the knife timing so that the knife will be operated as soon as thread nipper spring on needle bar tightens the upper thread.

#### 4) Loose upper tension

- CAUSE:** In case of loose main tension regulator discs.  
**ADJUSTMENT:** Adjust the upper thread being tightened by thumb screw when thread nipper lever roller is positioned at circumference of feed cam.

#### 5) Upper thread jamming

- CAUSE:** In case of the upper thread not being tightened by thread nipper spring on needle bar at the first stitch.  
**ADJUSTMENT:** Adjust thread nipper spring on needle bar so that it is tightened at the range of the needle being pulled out of needle hole until at its highest position. Loosened main tension discs will be tightened until the needle bar is raised up at its highest position.



## CHAPTER III TROUBLE SHOOTING

### 1. Thread tension mechanism

#### 1) Thread-off at the beginning

(1) CAUSE:

ADJUSTMENT: In case of loose tension on thread nipper spring on Refer 7, Adjustment on thread nipper mechanism. Page 30.

(2) CAUSE:

ADJUSTMENT: In case of wrong positioning of thread retainer. Set thread retainer to catch the upper thread at the position of thread retainer is referred to 5. Adjustment on trimming mechanism. Page 22.

(3) CAUSE:

ADJUSTMENT: In case of short thread end after trimming. At the final stitch, set the timing of tension release, thread nipper on needle bar, and functioning of knives.

#### 2) Thread breakage at the machine's stop

CAUSE:

ADJUSTMENT: In case of not being loosen on main tension regulator at the final stitch, set the timing of tension release, thread nipper on needle bar, and functioning of knives.

#### 3) Untidy length of thread end from needle

CAUSE:

ADJUSTMENT: In case of the upper thread being trimmed by knife before tightening the upper thread by thread nipper spring on needle bar. Adjust the knife timing so that the knife will be operated as soon as the thread nipper spring on needle bar tightens the upper thread.

#### 4) Loose upper tension

CAUSE:

ADJUSTMENT: In case of loose main tension regulator discs. Adjust the upper thread being tightened by thumb screw when thread nipper lever roller is positioned at circumference of feed cam.

#### 5) Upper thread jamming

CAUSE:

ADJUSTMENT: In case of the upper thread not being tightened by thread nipper spring on needle bar at the first stitch. Adjust thread nipper spring pulled out of needle hole until at its highest position. Loosened main tension discs will be tightened until the needle bar is raised up at its highest position.

## 2. Thread trimming mechanism

### 1) Upper thread not being trimmed

(1) CAUSE: Wrong setting of upper thread knife.

ADJUSTMENT: Refer to 5. Adjustment on thread trimming mechanism, Page 22.

(2) CAUSE: Wrong timing of upper thread knife hooks the upper thread loop.

ADJUSTMENT: Adjust knife cam (B) by loosening screws so that upper thread knife may hook the upper thread loop during hook point travelling with the range of 90°~135° at the final stitch.

(3) CAUSE: Wrong position of upper thread knife.

ADJUSTMENT: After upper thread knife is operated, adjust the position of upper thread knife to be positioned at the needle hole. Page 24.

(4) CAUSE: In case of excessive looseness of upper thread prior to thread trimming.

ADJUSTMENT: Adjust pressure of sub tension regulator because too long thread is pulled although knife hooks the loop to trim the thread. Also adjust timing of loosening main tension at the final stitch.

(5) CAUSE: Dull knife edge.

ADJUSTMENT: Sharpen knife edge or replace.

### 2) Lower thread not being trimmed

(1) CAUSE: Wrong setting of lower thread knife.

ADJUSTMENT: Refer to 5. Adjustment on thread trimming mechanism.

(2) CAUSE: Wrong timing to hook lower thread by lower thread knife.

ADJUSTMENT: Adjust lower thread knife to hook the lower thread at the time when roller stud is at the first recess portion of knife cam B.  
Refer to 5. 2) Timing of knife cam A. and B.

(3) CAUSE: Too weak tension on lower thread.

ADJUSTMENT: Adjust bobbin case spring tension.

(4) CAUSE: Blunt knife edge.

ADJUSTMENT: Sharpen the knife or replace.

### 3) Needle breakage

(1) CAUSE: Wrong setting of knives.

ADJUSTMENT: Refer to 5. Adjustment on thread trimming mechanism.

(2) CAUSE: In case that markings on segment and rack is out of order.

ADJUSTMENT: Set the timing marks. (NOTE: Make sure on play)

(3) CAUSE: In case that timing on knife and needle is out of order and position if not correct.

ADJUSTMENT: Refer to 5. Adjustment on thread trimming mechanism.

### 3. Clutch mechanism

#### 1) Mal-function on belt shift

(1) CAUSE: Improper length of belt.

ADJUSTMENT: Proper length of belt is 30~40mm shorter than the length that it sets temporarily between pulleys of the machine head and the motor.

(2) CAUSE: Wrong position of belt shifter.

ADJUSTMENT: Adjust the position of belt shifter on the condition of idling and low and high speed operations.  
Refer to 3. 2) Adjusting belt shifter.

#### 2) Machine does not run at top speed

(1) CAUSE: Improper length of belts.

ADJUSTMENT: Change the length correctly.

(2) CAUSE: Slippage due to oil.

ADJUSTMENT: Make sure not to oil excessively on the upper shaft bushing (rear).

#### 3) Machine does not stop

CAUSE: Wrong height of clutch lever pawl.

ADJUSTMENT: Refer to 3. 2) Adjusting height of clutch lever pawl.

#### 4) Machine does not run at low speed

CAUSE: Wrong position of belt shifter.

ADJUSTMENT: Refer to 3. 2) Adjusting belt shifter. Page 17, 18.

#### 5) Irregular stop position

(1) CAUSE: Wrong position of stop cam.

ADJUSTMENT: Adjust timing of contact between stop cam and clutch stopper.  
Refer to 3. 3) (1) Timing of stop cam and clutch stopper.

(2) CAUSE: Too weak tension of stopper spring.

ADJUSTMENT: Refer to 3. 5) Pressure of stopper spring A.

(3) CAUSE: Machine stops without speed reduction.

ADJUSTMENT: Adjust belt shifter.

#### 6) Abnormal noise at stop position.

(1) CAUSE: Machine stops without speed reduction.

ADJUSTMENT: Adjust belt shifter.

(2) CAUSE: Too strong tensions on clutch lever spring and stopper spring.

ADJUSTMENT: Adjust tensions to be proper.

(3) CAUSE: Too much plays between bulge of stop cam and clutch stopper.

ADJUSTMENT: Adjust clutch stopper latch to be 3mm clearance between bulge of stop cam and clutch stopper.

#### 7) Mal-function on clutch lever.

(1) CAUSE: Wrong position of clutch stop latch and clutch lever catch.

ADJUSTMENT: Refer to 3. 1) Adjustment on clutch mechanism.

(2) CAUSE: Wrong adjustment on clutch actuating lever.  
ADJUSTMENT: Refer to 8.1) Adjusting clutch actuating lever.

(3) CAUSE: Wrong adjustment on drive connecting bar.  
ADJUSTMENT: Refer to 6. Adjustment on safety mechanism.

#### 8) Belts off

(1) CAUSE: Wrong position of clutch cam lever stopper.  
ADJUSTMENT: Adjust position, refer to 3. 2) (2)

(2) CAUSE: Wrong adjustment of clutch actuating lever.  
ADJUSTMENT: Refer to 8. 1) Adjusting clutch actuating lever.

### 4. Feed mechanism

#### 1) Needle breakage

CAUSE: Wrong timing of feed mechanism.  
ADJUSTMENT: Refer to 2. 1) Adjustment on feed mechanism.

#### 2) Irregular tack design against work clamp opening.

(1) CAUSE: Wrong centre of length feed movement.

(2) CAUSE: Wrong centre of width feed movement.

ADJUSTMENT: Refer to 2. Adjustment on feed mechanism.

### 5. Needle bar and hook mechanism

#### 1) Needle breakage and bending

CAUSE: Needle hits hook point.  
ADJUSTMENT: Adjust clearance to be 0.03~0.05mm between needle and hook by turning adjusting ring.  
Refer to 1.5)

#### 2) Skip stitch

(1) CAUSE: Too much or less clearance between hook point and needle.  
ADJUSTMENT: Same as above.

(2) CAUSE: Wrong timing of hook point and needle and wrong needle bar height.  
ADJUSTMENT: Adjust height of needle bar by shuttle driver so that the hook point is in line with the centre axis of the needle when needle bar raises up 3.5mm as standard measurement.  
Refer to 1. 3) & 1. 4) Page 12, 13

#### 3) Thread breakage only one or two plys of three ply thread.

(1) CAUSE: Scratches on thread guides and hook, etc.  
ADJUSTMENT: Eliminate them by sand paper or grind stone.

(2) CAUSE: Blunt needle.  
ADJUSTMENT: Replace.

**4) Thread jamming**

(1) CAUSE:

Out of timing on hook and needle.

ADJUSTMENT: Adjust timing depending on materials and thread.

(2) CAUSE:

Wrong thread pulling out.

ADJUSTMENT: Adjust clearance between shuttle driver and hook, standard measurement is 0.3~0.5mm.

(3) CAUSE:

Wrong function or tension of thread take up spring.

ADJUSTMENT: Adjust tension of thread take up spring to get proper supply of the upper thread depending on materials and thread.